

MODEL NOS.	MODEL NOS.
0556542	0556541
1856512	1556511
1856542	1556541
3056512	2556511
3056542	2556541
NATURAL GAS ONLY	LIQUEFIED PETROLEUM (L.P.) GAS ONLY

Save This Manual For Future Reference

## INFRARED UNVENTED NATURAL/PROPANE GAS HEATER

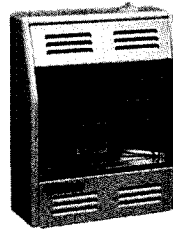

5,000 B.T.U.

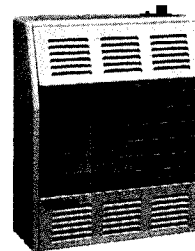

15,000 B.T.U.  
and  
18,000 B.T.U.

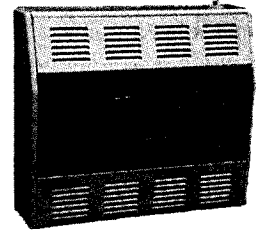

25,000 B.T.U.  
and  
30,000 B.T.U.



Installation must conform to local codes. In the absence of local codes, installation must conform with the current:

National Fuel Gas Code  
ANSI Z223.1  
and  
ANSI Z21.11.2



In Canada:  
CAN/CGA B149.1

Natural Gas Installation Code or CAN/CGA B149.2 Propane/LP Installation Code

Unvented room heaters are for installation in SINGLE FAMILY TYPE DETACHED RESIDENCES ONLY, and the installation is limited to ONE (1) unit per residence. Unvented room heaters are only to be used as supplementary heat and NOT AS PRINCIPAL SOURCE OF HEAT for the room in which the unit is installed.

Unvented room heaters are for installation in rooms having space which shall limit the appliance input to a maximum of "20 BTUH" per cubic foot of room space. Unvented room heaters are NOT TO BE USED IN BEDROOMS, MOBILE HOMES, TRAILERS AND RECREATIONAL VEHICLES.

**EXCEPTION:** If local codes permit, models 0556542 and 0556541 may be used in a bedroom, mobile home, and bathroom (check local codes prior to installation).

In the Canadian provinces of British Columbia and Manitoba, unvented heaters shall be limited to those having INPUT RATINGS OF UP TO 25,000 BTU PER HOUR MAXIMUM.

Unvented room heaters are NOT FOR COMMERCIAL OR INDUSTRIAL USE.

**WARNING:** Improper installation, adjustment, alteration, service or maintenance can cause injury or property damage. Refer to this manual. For assistance or additional information, consult a qualified installer, service agency or the gas supplier.

**This is an unvented gas-fired heater. It uses air (oxygen) from the room in which it is installed. Provisions for adequate combustion and ventilation air must be provided. Refer to page 6.**

**WARNING:** If the information in this manual is not followed exactly, a fire or explosion may result, causing property damage, personal injury or loss of life.

- Do not store or use gasoline or other flammable vapors and liquids in the vicinity of this or any other appliance.
- WHAT TO DO IF YOU SMELL GAS
  - Do not try to light any appliance.
  - Do not touch any electrical switch; do not use any phone in your building.
  - Extinguish any open flame.
  - Immediately call your gas supplier from a neighbor's phone. Follow the gas supplier's instruction.
  - If you cannot reach your gas supplier, call the fire department.
- Installation and service must be performed by a qualified installer, service agency or the gas supplier.

# Contents

Williams Installation Policy.....	2	Locating Unvented Gas Heater.....	7
Introduction.....	3	Clearances.....	7
Basic Description.....	3	Installation.....	8
Helpful Installation Information.....	3	Gas Supply and Piping Requirements.....	9-11
Safety Rules.....	4	Operating The Unvented Gas Heater.....	12-15
Unpack Your Unvented Gas Heater.....	5	How To Care For Your Unvented Gas Heater.....	16
Basic Tools Needed.....	5	Troubleshooting.....	17-19
Basic Materials.....	5	Replacement Parts.....	20-28
Optional Accessories.....	5	Accessory Installation.....	29-30
Provisions For Adequate Combustion and Ventilation Air.....	6		

## Your Warranty

The Manufacturer, Williams Furnace Co., warrants this wall furnace or heater to the original purchaser under the following conditions:

### LIMITED ONE-YEAR WARRANTY

1. Any part thereof which proves to be defective in material or workmanship within one year from date of original purchase for use will be repaired or replaced at the Manufacturer's option, FOB its factory.
2. No liability is assumed by the Manufacturer for removal or installation labor costs, nor for freight or delivery charges.

### LIMITATIONS

1. THIS LIMITED WARRANTY IS THE ONLY WARRANTY MADE BY THE MANUFACTURER. IMPLIED WARRANTIES OF MERCHANTABILITY OR FITNESS FOR ANY PARTICULAR PURPOSE ARE LIMITED TO THE SAME ONE YEAR TERM AS THIS EXPRESS WARRANTY. UNDER NO CIRCUMSTANCES SHALL THE MANUFACTURER BE LIABLE FOR INCIDENTAL, CONSEQUENTIAL, SPECIAL OR CONTINGENT DAMAGES OR EXPENSES ARISING DIRECTLY OR INDIRECTLY FROM ANY DEFECT IN THE PRODUCT OR ANY COMPONENT OR FROM THE USE THEREOF. THE REMEDIES SET FORTH HEREIN ARE THE EXCLUSIVE REMEDIES AVAILABLE TO THE USER AND ARE IN LIEU OF ALL OTHER REMEDIES.

Some states do not allow limitations on how long an implied warranty lasts, and some states do not allow the exclusion or limitation of incidental or consequential damages, so the above limitations or exclusions may not apply to you.

2. This warranty does not include any charge for labor or installation.
3. This warranty does not extend to painted surfaces nor to damage or defects resulting from accident, alteration, misuse or abuse, or improper installation.
4. This warranty does not cover claims which do not involve defective workmanship or materials.

### DUTIES OF THE CONSUMER

1. The heating equipment must be installed by a qualified installer and operated in accordance with the installation and homeowner's instructions furnished with the equipment.
2. Any travel, diagnostic costs, service labor, and labor to repair the defective unit will be the responsibility of the owner.
3. A bill of sale, cancelled check, payment record or permit should be kept to verify purchase date to establish the warranty period.
4. Have the installer enter the requested information in the space below.

### GENERAL

1. The Manufacturer neither assumes nor authorizes any person to assume for it any other obligation or liability in connection with said equipment.
2. Service under this warranty should be obtained by contacting your dealer. Provide the dealer with the model number, serial number and purchase date verification.
3. If, within a reasonable time after contacting your dealer, satisfactory service has not been received, contact: Customer Service Department, 225 Acacia St., Colton, CA 92324, for assistance.
4. THIS WARRANTY GIVES YOU SPECIFIC LEGAL RIGHTS, AND YOU MAY ALSO HAVE OTHER RIGHTS WHICH VARY FROM STATE TO STATE.

### INSTALLATION INFORMATION

Model No. \_\_\_\_\_ Serial No. \_\_\_\_\_

Orig. Purchaser \_\_\_\_\_

Address \_\_\_\_\_

City and State \_\_\_\_\_ Zip \_\_\_\_\_

Dealer \_\_\_\_\_

Address \_\_\_\_\_

City and State \_\_\_\_\_ Zip \_\_\_\_\_

Installation date \_\_\_\_\_ Signed by \_\_\_\_\_ (Dealer or authorized

representative who certifies that this appliance has been installed in accordance with Manufacturer's instructions and local codes.

# Introduction

Please read our instructions before you install and use your heater. This will help you obtain the full value from this heater. It could help you avoid needless service costs, if the answer to the problem is found within this instruction manual. If the answer is not found - call our Customer Service Department at (909) 825-0993 before returning the heater to your supplier.

Today's homes are built more energy efficient than ever. New materials, increased insulation and new construction methods help reduce heat loss in homes. Homeowners weather strip and caulk around windows and doors to keep the cold air out and the warm air in. During heating months, homeowners want their homes as airtight as possible. While it is good to make your home energy efficient, your home needs to breathe. Fresh air must enter your home. All fuel-burning appliances need fresh air for proper combustion and ventilation.

---

## Basic Description

Unvented heaters are shipped ready to install. No electric power is needed for the heater except when the optional accessory blower is used. Then, a standard 3 prong receptical (electrical outlet) is needed near the heater.

Always consult your local heating or plumbing inspector, building department or gas utility company regarding regulations, codes or ordinances which apply to the installation of an unvented heater.

The heater contains a single multi-slot gas burner.

Combustion air is drawn to the heater from the room in which it is installed. It must receive enough air to enable it to operate properly. See page 6 of this instruction manual for more information.

Convection causes room air to circulate from the floor upward along the front, back, and sides of the heater, and then back to the room.

The heater cabinet is built of heavy gauge steel treated for corrosion resistance and has an enamel paint finish. The heater controls are located on the top of the cabinet. All models are equipped with AGA/CGA listed gas valves and pilots.

### PIEZO IGNITION SYSTEM

This unit has a piezo ignitor. This system requires no matches, batteries, or other sources to light the heater.

### THERMOSTATIC HEAT CONTROL

Thermostat models have a thermostat sensing bulb and a control valve. This results in the greatest heat comfort. This can also result in lower gas bills.

### SAFETY DEVICE

This unit has a pilot with an Oxygen Depletion Sensor shutoff system (ODS). The ODS/pilot is a required feature for unvented room heaters. The Oxygen Depletion Sensor is rated for operation at altitudes up to 7,000 feet. The ODS/pilot shuts off the heater if there is not enough fresh air. When the normal oxygen content (approx. 21%) is reduced to 18%, the pilot and main burner will turn off and cannot be re-lit. When the pilot flame is extinguished by wind or interruption of gas supply, it will also turn off. Re-lighting is possible in this condition.

---

## Helpful Installation Information

The following booklets will help you in making the installation:

ANSI/NFPA 70, or current edition "National Electrical Code." In Canada: CSA C22.1 Canadian Electrical Code.  
American National Standard Z223.1 or current edition "National

Fuel Gas Code", also known as NFPA 54. In Canada: CAN/CGA B149.

Obtain from - American National Standards Institute, Inc., 1430 Broadway, New York, N.Y. 10018.

# Safety Rules

## WARNING

READ THESE RULES AND THE INSTRUCTIONS CAREFULLY. FAILURE TO FOLLOW THESE RULES AND INSTRUCTIONS COULD CAUSE A MALFUNCTION OF THE HEATER. THIS COULD RESULT IN DEATH, SERIOUS BODILY INJURY, AND/OR PROPERTY DAMAGE.

INSTALLATION MUST CONFORM TO LOCAL CODES. IN THE ABSENCE OF LOCAL CODES, INSTALLATION MUST CONFORM WITH THE NATIONAL FUEL GAS CODE, ANSI Z223.1.

INSTALLATION AND REPAIR SHOULD BE DONE BY A QUALIFIED SERVICE TECHNICIAN. THE APPLIANCE SHOULD BE INSPECTED BEFORE USE AND AT LEAST ANNUALLY BY A PROFESSIONAL SERVICE TECHNICIAN. MORE FREQUENT CLEANING MAY BE REQUIRED DUE TO EXCESSIVE LINT FROM SOME CARPETING, BEDDING MATERIAL, ETC. IT IS IMPERATIVE THAT CONTROL COMPARTMENTS, BURNERS AND CIRCULATING AIR PASSAGEWAYS OF THE APPLIANCE BE KEPT CLEAN.

## SEE CARBON MONOXIDE WARNING ON PAGE 10.

YOUNG CHILDREN SHOULD BE CAREFULLY SUPERVISED WHEN THEY ARE IN THE SAME ROOM WITH THE APPLIANCE.

ANY SAFETY SCREEN, GUARD OR PARTS REMOVED FOR SERVICING AN APPLIANCE MUST BE REPLACED PRIOR TO OPERATING THE APPLIANCE TO AVOID PROPERTY DAMAGE, BODILY INJURY OR DEATH.

CHILDREN AND ADULTS SHOULD BE ALERTED TO THE HAZARD OF HIGH SURFACE TEMPERATURE AND SHOULD STAY AWAY TO AVOID BURNS OR CLOTHING IGNITION.

DUE TO HIGH TEMPERATURES, THE APPLIANCE SHOULD BE LOCATED OUT OF TRAFFIC AND AWAY FROM FURNITURE AND DRAPERIES.

WARNING: ANY CHANGE TO THIS HEATER OR ITS CONTROLS COULD CAUSE INJURY OR DEATH.

1. USE ONLY MANUFACTURER'S REPLACEMENT PARTS. USE OF ANY OTHER PARTS COULD CAUSE INJURY OR DEATH.
2. BE SURE heater is for type of gas to be used. Do not change it to use other gases. Unsafe operation could result and could cause bodily injury and death.

## WARNING

DO NOT USE THIS UNVENTED ROOM HEATER IF ANY PART HAS BEEN UNDER WATER. IMMEDIATELY CALL A QUALIFIED SERVICE TECHNICIAN TO INSPECT THE UNVENTED ROOM HEATER AND TO REPLACE ANY PART OF THE CONTROL SYSTEM AND ANY GAS CONTROL WHICH HAS BEEN UNDER WATER.

3. It is prohibited to install the heater in a bedroom, trailer or recreational vehicle/mobile home, etc (see exceptions on page 1). If installed in a garage or basement, heater must be a minimum of 24" above the floor.
4. USE joint compound (pipe dope) on threaded joints of gas piping that is resistant to the action of liquefied petroleum gas.
5. USE only ground joint unions in gas piping.
6. INSTALL a manual shutoff valve and union ahead of the controls so that the controls and heater may be removed for servicing, if necessary.
7. INCLUDE a 1/8 NPT plugged tapping accessible for test gauge connection immediately upstream of the gas supply connection to the heater.
8. NEVER test for gas leaks with an open flame. Use soap suds to check all gas connections. This will avoid the possibility of fire or explosion.
9. **Turn off heater and let cool before servicing.** Only a qualified service person should service and repair heater.
10. DO NOT PLACE CLOTHING OR OTHER FLAMMABLE MATERIAL ON OR NEAR THE APPLIANCE.
11. DO NOT modify or alter the heater in any way.
12. CLEAN the heater and periodically inspect the pilot and burner flame as described in the maintenance section of this manual.
13. DISCONNECT the heater during supply line pressure testing. See page 10.
14. FOLLOW the lighting and operating procedures given in this manual.
15. Since the vent-free gas heaters may easily increase the amount of humidity in the room, the larger the burner size the more humidity present. This can cause excessive moisture accumulation on windows and other surfaces.
16. If L.P. gas is required, the L.P. supply tank must be placed outside the house. It must be installed in a well ventilated area away from the house. The distances must be placed as prescribed by the law. Check local and state codes and laws in order to comply with proper safety requirements.

# Unpack Your Unvented Gas Heater

The heater is shipped assembled. The cabinet must be removed for the heater installation.

1. Open carton and carefully lift out heater.
2. Stand heater upright.
3. Hardware included with heater:
  - (2) metal mounting brackets
  - (4) screws
  - (4) plastic anchors
  - (1) mounting bracket paper template

4. Properly dispose of shipping material.

## NOTE

Check the burner rating plate, located inside the cabinet on the bottom, to make sure your heater is equipped to operate on the type of gas available (either Natural or L.P. Gas). DO NOT convert the heater from Natural Gas to L.P. Gas or from L.P. Gas to Natural Gas.

---

## Basic Tools Needed

Pipe Wrenches  
Screwdriver  
6 ft. folding rule or tape  
Level

Pipe cutting and threading tools  
Black iron gas pipe and fittings - 1/2"  
Gloves and safety glasses

---

## Basic Materials

- \* Pipe and fittings to make connections to heater.
- \* Pipe Joint Compound resistant to L.P. gases.
- \* Electrical wiring supplies as needed.

- \* Minimum wire size is #14 gauge copper.
- \* Electrical supplies only required if accessory blower is being installed.

---

## Optional Accessories

### Floor Base

See Figure 1

Kit 4287 may be used with models:  
1556511; 1556541; 1856512;  
1856542

Kit 4288 may be used with models:  
2556511; 2556541; 3056512;  
3056542

### Blower

See Figure 2

Kit 2205 (thermostat) may be used with models:  
1556511; 1556541; 1856512; 1856542;  
2556511; 2556541; 3056512; 3056542

Kit 2206 (manual) may be used with models:  
1556511; 1556541; 1856512; 1856542;  
2556511; 2556541; 3056512; 3056542

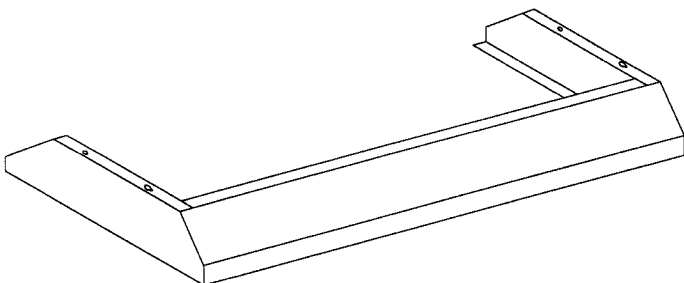

FIGURE 1

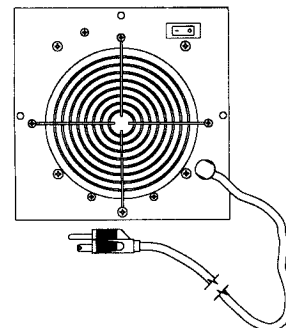

FIGURE 2

# PROVISIONS FOR ADEQUATE COMBUSTION AND VENTILATION AIR

## WARNING

This heater shall not be installed in a confined space unless provisions are provided for adequate combustion and ventilation air.

The National Fuel Gas Code, ANSI Z223.1 defines a **confined space** as a space whose volume is less than 50 cubic feet per 1,000 BTU per hour (4.8 m<sup>3</sup> per kw) of the aggregate input rating of all appliances installed in that space and an **unconfined space** as a space whose volume is not less than 50 cubic feet per 1,000 BTU per hour (4.8 m<sup>3</sup> per kw) of the aggregate input rating of all appliances installed in that space. Rooms communicating directly with the space in which the appliances are installed, through openings not furnished with doors, are considered a part of the unconfined space.

## SUPPLYING ADEQUATE VENTILATION

The following information will help you classify your space and provide adequate ventilation.

**Unusually tight construction** is defined as construction where:

- walls and ceilings exposed to the outside atmosphere have a continuous water vapor retarder with a rating of one perm ( $6 \times 10^{-11}$  kg per pa-sec-m<sup>2</sup>) or less with openings gasketed or sealed and
- weather stripping has been added on openable windows and doors and
- caulking or sealants are applied to areas such as joints around window and door frames, between sole plates and floors, between wall-ceiling joints, between wall panels, at penetrations for plumbing, electrical and gas lines and at other openings.

If your home meets all of the three criteria above, you must provide additional fresh air.

## WARNING

If the area in which the heater may be operated is smaller than that defined as an unconfined space or if the building is of unusually tight construction, provide adequate combustion and ventilation air by one of the methods described in the *National Fuel Gas Code, ANSI Z223.1*, Section 5.3 or applicable local codes.

## DETERMINING IF YOU HAVE A CONFINED OR UNCONFINED SPACE.

Use this worksheet and examples to determine if you have a confined or unconfined space.

**Space:** Includes the room in which you will install heater plus any adjoining rooms with doorless passageways or ventilation grills between the rooms.

- Determine the volume of the space (length x width x height).  
Length x Width x Height = \_\_\_\_\_ cu. ft. (volume of space)

*Example:* Space size 22 ft. (length) x 18 ft. (width) x 8 ft. (ceiling height) = 3,168 cu. ft. (volume of space)

If additional ventilation to adjoining room is supplied with grills or openings, add the volume of these rooms to the total volume of the space.

- Divide the space volume by 50 cubic feet to determine the maximum BTU/Hr the space can support.  
(volume of space) divided by 50 cu. ft. = (Maximum BTU/Hr the space can support.)

*Example:* 3,168 cu. ft. (volume of space) divided by 50 cu.ft. = 63.36 or 63,360 (maximum BTU/Hr the space can support)

- Add the BTU/Hr of all fuel burning appliances in the space.

Gas water heater*	_____	BTU/Hr
Gas furnace	_____	BTU/Hr
Vented gas heater	_____	BTU/Hr
Gas fireplace logs	_____	BTU/Hr
Other gas appliances* +	_____	BTU/Hr
Total	= _____	BTU/Hr

*Example:* Gas Furnace 30,000BTU/Hr  
Vent-free heater +39,000BTU/Hr  
Total =69,000BTU/Hr

\*Do not include direct-vent gas appliances. Direct-vent draws combustion air from the outdoors and vents to the outdoors.

- Compare the maximum BTU/Hr the space can support with the actual amount of BTU/Hr used.

\_\_\_\_\_ BTU/Hr (maximum the space can support)  
\_\_\_\_\_ BTU/Hr (actual amount of BTU/Hr used)

*Example:* 63,360 BTU/Hr (maximum the space can support)  
69,000 BTU/Hr (actual amount of BTU/Hr used)

The space in the above example is a confined space because the actual BTU/Hr used is more than the maximum BTU/Hr the space can support. You must provide additional fresh air. Your options are as follows:

- Rework worksheet, adding the space of an adjoining room. If the extra space provides an unconfined space, remove door to adjoining room or add ventilation grills between rooms. See *Ventilation Air From Inside Building*.
- Install a lower BTU/Hr heater, if lower BTU/Hr size makes room unconfined.

If the actual BTU/Hr used is less than the maximum BTU/Hr the space can support, the space is an unconfined space. You will need no additional fresh air ventilation.

## VENTILATION AIR FROM INSIDE BUILDING

This fresh air would come from an adjoining unconfined space. When ventilating to an adjoining unconfined space, you must provide two permanent openings: one within 12" of the ceiling and one within 12" of the floor on the wall connecting the two spaces. You can also remove door into adjoining room.

## VENTILATION AIR FROM OUTDOORS

Provide extra fresh air by using ventilation grills or ducts. You must provide two permanent openings: one within 12" of the ceiling and one within 12" of the floor. Connect these items directly to the outdoors or spaces open to the outdoors. These spaces include attics and crawl spaces. Follow the *National Fuel Gas Code NFPA 541ANSI Z223.1, Section 5.3, Air for Combustion and Ventilation* for required size of ventilation grills or ducts.

**IMPORTANT.** Do not provide openings for inlet or outlet air into attic if attic has a thermostat-controlled power vent. Heated air entering the attic will activate the power vent.

## IN CANADA:

When combustion air supply is for the unvented room heater only, it shall be sized at the rate of one (1) square inch per 1000 BTU (.29KW) from outdoors. However, combustion air is acceptable when available from the principal heat source and sized to the current CAN/CGA B149.1 or .2 requirements. Where unvented equipment is installed in an area separated from a combustion air supply by a door, then permanent openings, grilles or louvers shall be provided. One shall be within 18 inches (46 cm) from the ceiling, and one 18 inches (46 cm) from the floor, sized to one (1) square inch per 1000 BTU (0.29 KW) to allow free movement of air with the source of combustion air supply.

# Locating Unvented Gas Heater

Consider the following points before attempting to install the heater:

1. This heater is designed to be mounted on a wall. It can also be located on the floor, away from the wall, using an optional floor mounting stand.
2. Select a location for the heater that will provide exposure of the radiant surface to the room, but will not be subjected to accidental contact. Adequate clearance must be available around the air opening.
3. Be sure to read the section "Provisions For Adequate Combustion and Ventilation Air" requirements before deciding where you install this heater. The heater must have enough fresh air suitable for proper combustion.
4. For proper combustion in the heater, provide one or more fresh air openings to the room where the heater is located.
5. This heater creates warm air currents that move heat to wall surfaces next to heater. Installing the heater next to vinyl or cloth wall coverings or operating heater where impurities in the air (such as tobacco smoke) exist, may discolor walls.

## CLEARANCES

Adequate clearances must be provided for accessibility for purposes of servicing and proper operation.

### WALL MOUNTED

1. Minimum clearance to adjacent walls - 12".
2. Minimum clearance to floor (top surface of carpeting, tile or other combustible material) - 6".
3. Minimum clearance between the heater and ceiling - 36".

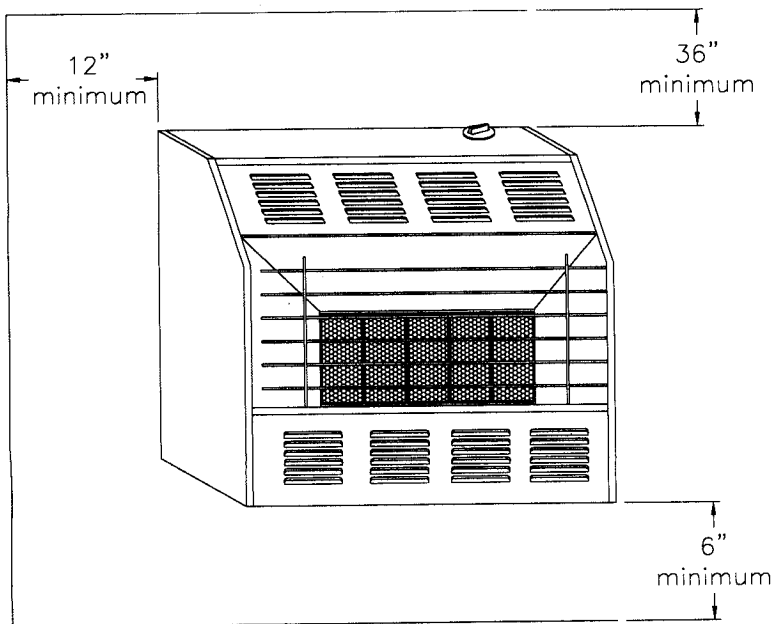

FIGURE 3

### FLOOR MOUNTED WITH OPTIONAL BASE

1. Minimum clearance between the heater and adjacent walls - 12".
2. Minimum clearance between the heater and ceiling - 36".

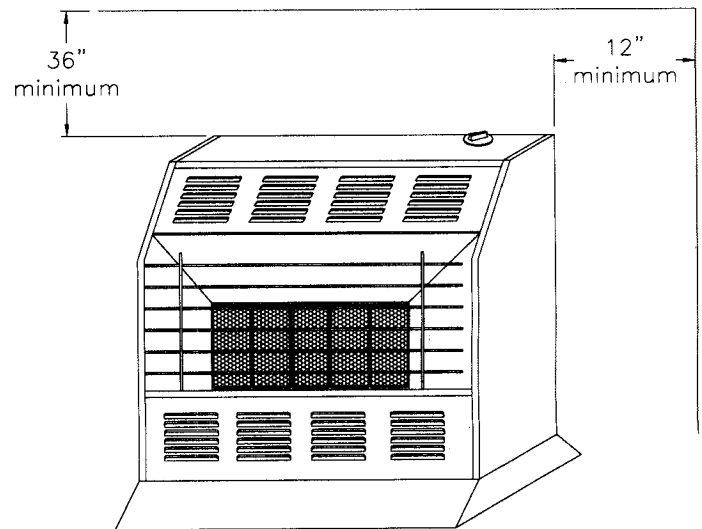
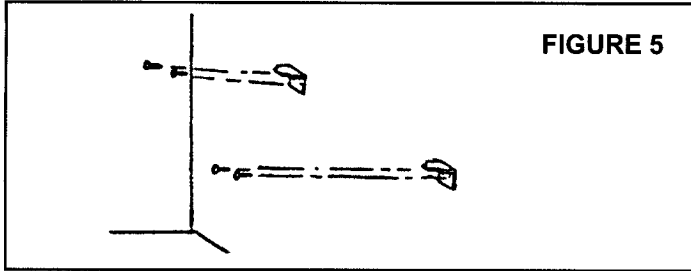

FIGURE 4

# Installation

Installation and repair should be done by a qualified service technician.

1. Install mounting brackets on wall. Use enclosed "paper template" for proper location of holes. It may be necessary to use plastic or lead anchors for plaster walls. These are standard hardware items, available locally.



2. After mounting brackets are installed, hang unvented room heater on mounting brackets in holes provided at the rear of the heater.

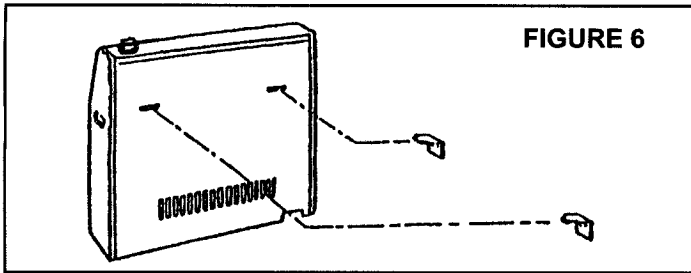

3. Figure 7 details the mounting bracket positions. This assures proper clearances once the heater is mounted on the wall. Use the paper template to locate the bracket height. See Figure 3 on page 7.
4. Maintain minimum clearances as specified in the "Clearances" section on page 7 of this manual.
5. If the unvented room heater is installed in a residential garage, the following precautions must be taken.
  - \* The heater pilot and burner must be at least 24 inches above the floor.
  - \* The heater must be located and protected, so as not to be subjected to damage by a moving vehicle.
  - \* All flammable fuels must be removed.
6. Connect the unvented room heater to the gas supply line as specified by the "Gas Supply and Piping Requirements" section on page 9 and 10 of this manual.
7. The floor mounting stand is required if floor mounted.

**WARNING: THIS INSTALLATION IS NOT COMPLETE UNTIL FLOOR MOUNTING STAND IS INSTALLED.**

An inspection of the heater and attached systems should be performed at least once each year by a qualified service technician. More frequent inspections are advisable if the heater is installed or operated in a manner that might cause the accumulation of dust or dirt in the heater, or the failure of component parts more rapidly than would normally be expected.

IN CANADA:

Installation must conform with local codes or, in the absence of local codes, with the current standard CAN/CGA - B149.1 Natural Gas Installation Code or CAN/CGA - B149.2 Propane Installation Code.

MODELS  
0556541  
0556542

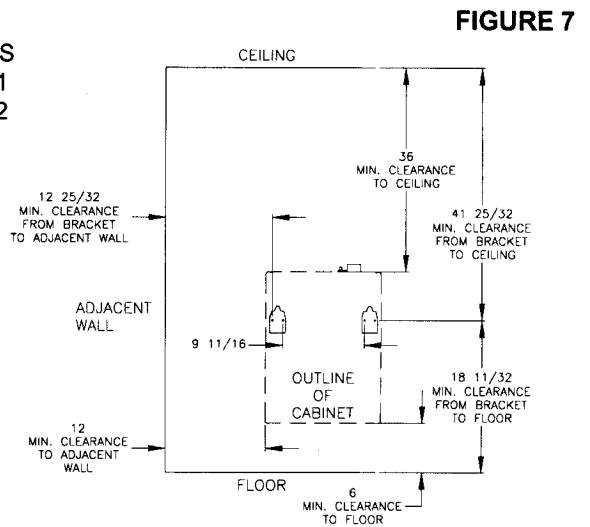

MODELS  
1556511  
1556541  
1856512  
1856542

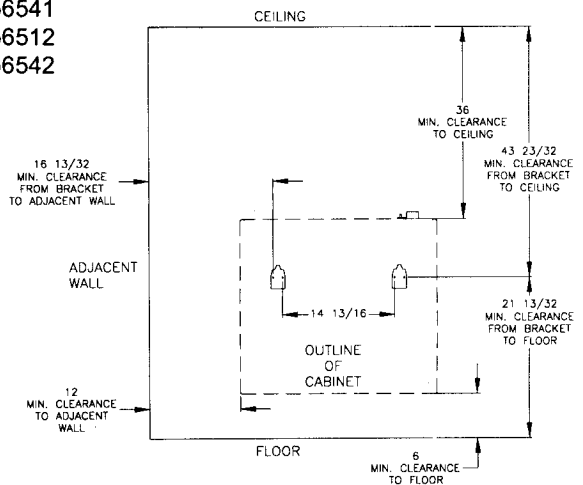

MODELS  
2556511  
2556541  
3056512  
3056542

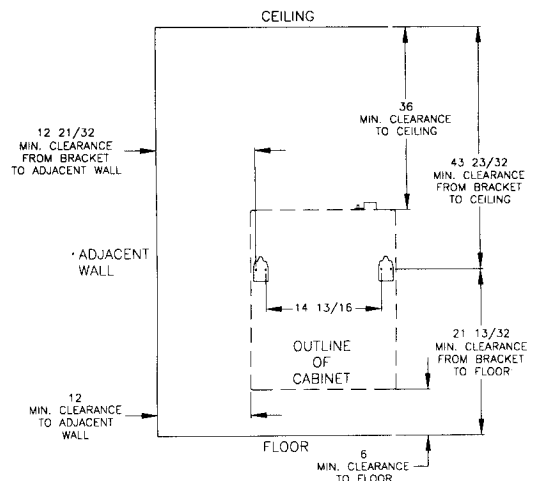

# Gas Supply And Piping Requirements

## GAS SUPPLY

If you are not sure what type gas is available in your locality, obtain this information from your local gas supply company prior to installing the heater.

The pilot and control system of this heater will automatically stop the gas flow to the pilot burner and main burner if the pilot flame is extinguished. This system also generates the electricity required to operate the thermostat system. Since no electrical power is required from any other source, this heater will continue to operate during a power outage, with the exception of the optional blower kit.

If installation is for L.P. Gas, have L.P. installer use two-stage regulation and make all connections from storage tank to heater.

Use two pipe wrenches when making the connection to the valve to prevent turning or damage to gas valve.

## PIPING

Gas pipe must be installed by a qualified installer.

The pipe system must comply with local codes and ordinances or with the latest edition of the American National Fuel Gas Code Z223.1.

1. The gas supply line must be of an adequate size to handle the BTU/hr requirements and length of the run for the unit being installed. Determine the minimum pipe size from Figure 9 basing the length of the run from the gas meter or source to the unit.
2. Use new, properly reamed pipe free from chips such as steel or black iron pipe and fittings or other approved by local codes.
3. Do not thread pipe too far. Valve distortion or malfunction may result from excess pipe within control.
4. Use moderate amount of good quality compound to pipe only, leaving 2 end threads bare. If L.P. gas installation, use compound resistant to action of liquefied petroleum gases.

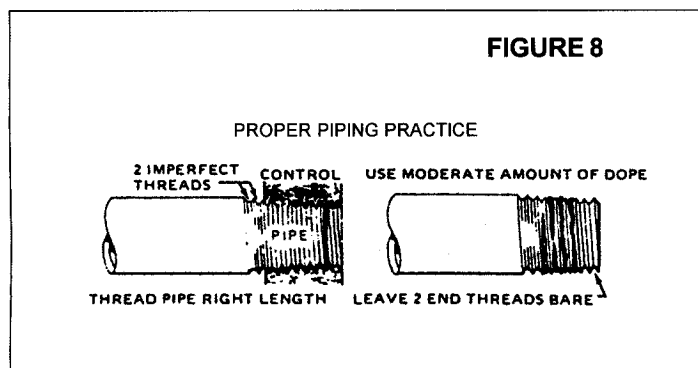

5. Use ground joint unions.
6. Install a drip leg (sediment trap). The drip leg is required to prevent condensate and scale particles from entering the gas valve. See Figure 10.
7. Install a manual shut-off valve.
8. Provide a 1/8 NPT test gauge connection immediately before the gas supply connection to the heater.
9. Do not locate pipe joints in a concealed location where leak detection and repairs are difficult or impossible.

**WARNING: ALL GAS PIPING AND CONNECTIONS MUST BE TESTED FOR LEAKS AFTER INSTALLATION OR SERVICING. ALL LEAKS MUST BE CORRECTED IMMEDIATELY.**

1. Make sure the control of the heater is in the "OFF" position.
2. Open the manual shut off valve. Test for leaks by applying a liquid detergent to all joints. Bubbles forming indicate a leak.
3. Correct any leak at once.

**CAUTION: NEVER USE AN OPEN FLAME TO CHECK FOR LEAKS.**

**FIGURE 9**

NATURAL GAS PIPE CAPACITY - BTU PER HOUR (INCLUDES FITTINGS) PIPE SIZE			
LENGTH OF PIPE - FEET	1/2 INCH	3/4 INCH	1 INCH
20	92,000	190,000	350,000
40	63,000	130,000	245,000
60	50,000	105,000	195,000
L.P. GAS PIPE CAPACITY - BTU PER HOUR (INCLUDES FITTINGS) PIPE SIZE			
LENGTH OF PIPE - FEET	1/2 INCH	3/4 INCH	1 INCH
20	189,000	393,000	732,000
40	129,000	267,000	504,000
60	103,000	217,000	409,000

# Gas Supply And Piping Requirements

## GAS PRESSURE CHECK

The heater regulator controls the gas pressure to the burner. The gas pressure should be checked at the pressure test point. Pressure should be checked with unit on high (refer to chart on back page for specified pressure).

The pressure test point for these models is a 1/8" npt plugged tap located at the bottom of the regulator (see illustration below). To gain access to the regulator, follow these steps:

1. Lift screen straight up. Pull bottom of screen out. Pull screen down and set aside.
2. Remove two (2) screws on bottom front panel. Remove bottom front panel and set aside.
3. Pressure test is at the regulator.

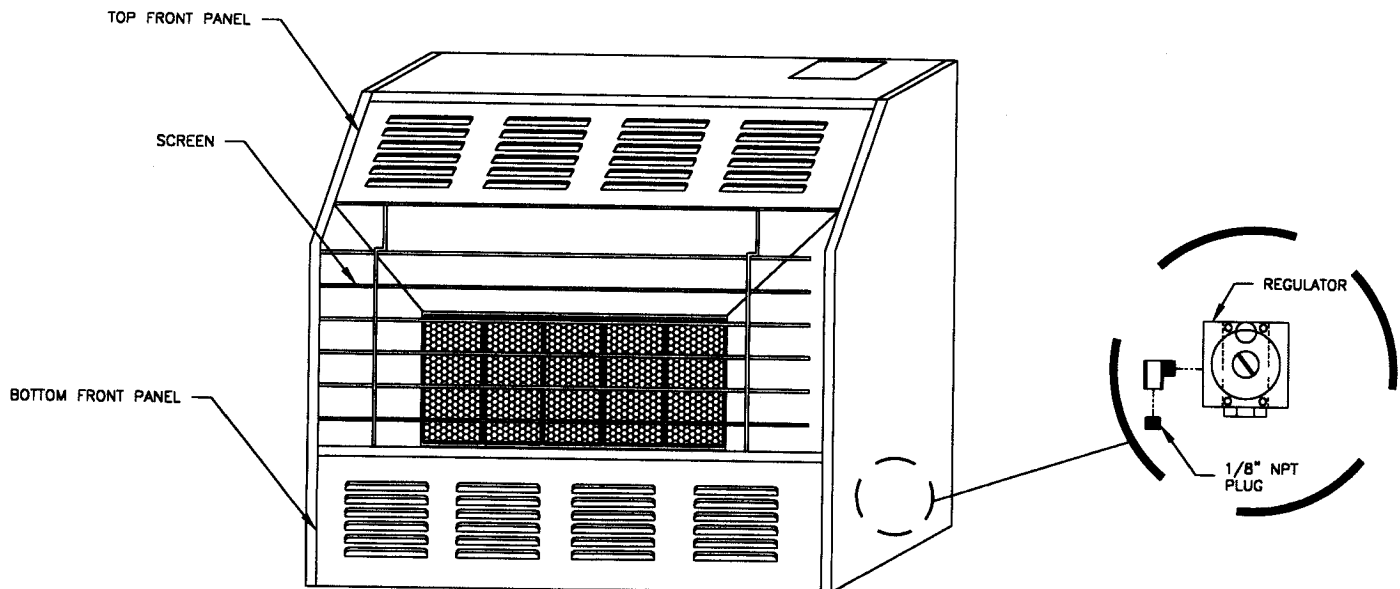

# Gas Supply And Piping Requirements

## WARNING

DANGER OF PROPERTY DAMAGE, BODILY INJURY OR DEATH.

MAKE SURE THE HEATER IS EQUIPPED TO OPERATE ON THE TYPE OF GAS AVAILABLE. MODELS DESIGNATED AS NATURAL GAS ARE TO BE USED WITH NATURAL GAS ONLY. HEATERS DESIGNATED FOR USE WITH LIQUIFIED PETROLEUM (L.P.) GAS HAVE ORIFICES SIZED FOR COMMERCIALLY PURE PROPANE GAS. THEY CANNOT BE USED WITH BUTANE OR A MIXTURE OF BUTANE AND PROPANE.

## WARNING

DANGER OF PROPERTY DAMAGE, BODILY INJURY OR DEATH.

NEVER USE A MATCH OR OPEN FLAME TO TEST FOR LEAKS. NEVER EXCEED SPECIFIED PRESSURES FOR TESTING. HIGH PRESSURES MAY DAMAGE THE GAS VALVE AND CAUSE OVER-FIRING WHICH MAY RESULT IN IMPROPER COMBUSTION AND POSSIBLE PRODUCTION OF CARBON MONOXIDE. LIQUID PETROLEUM (L.P.) IS HEAVIER THAN AIR AND IT WILL SETTLE IN ANY LOW AREA, INCLUDING OPEN DEPRESSIONS, AND IT WILL REMAIN THERE UNLESS AREA IS VENTILATED.

**IMPORTANT:** Hold pressure regulator with wrench when connecting it to gas piping and/or fittings.

**NEVER ATTEMPT STARTUP OF UNIT BEFORE THOROUGHLY VENTILATING AREA.**

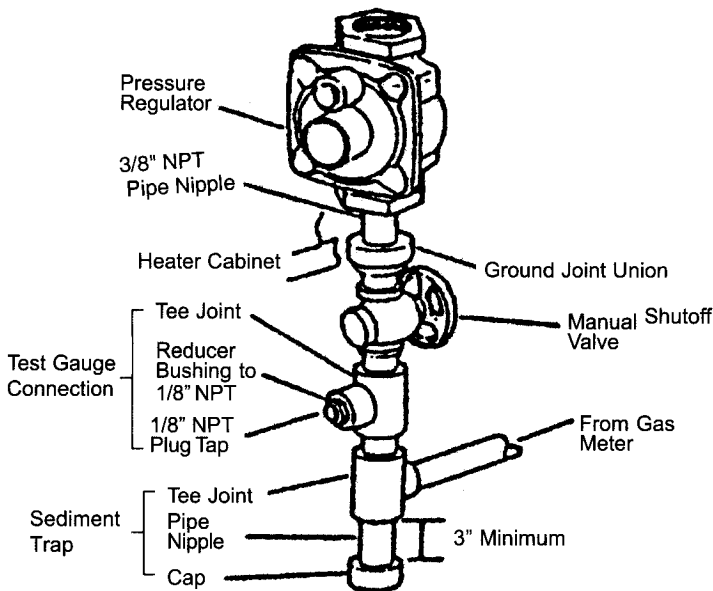

FIGURE 10

The maximum inlet supply pressure for this heater must be 7.0 inches for natural gas and 14 inches for LP gas. The minimum inlet supply pressure for the purpose of input adjustment must be 6 inches for natural gas and 11 inches for LP gas. The control on this heater is equipped with a regulator which reduces the manifold pressure to 5 inches for natural gas and 10 inches for LP gas.

## PRESSURE TESTING SUPPLY LINE

**CAUTION:** The unvented room heater and its individual shutoff valve must be disconnected from the gas supply piping system during pressure testing of that system at test pressures in excess of 1/2 psig(3.5 kPa). The unvented room heater must be isolated from the gas supply piping system by closing its individual manual shutoff valve during any pressure testing of the gas supply piping system at test pressures equal to or less than 1/2 psig(3.5 kPa). Pressures in excess of 1/2 psig(3.5 kPa) will cause damage to the control valve and may cause damage to the shutoff valve.

\* \* \* \* \*

**WARNING: CARBON MONOXIDE IS A POISONOUS, COMBUSTIBLE GAS FORMED BY INCOMPLETE COMBUSTION. IT IS COLORLESS, ODORLESS AND TASTELESS. DEPENDING ON THE LENGTH OF EXPOSURE AND THE AMOUNT INHALED, CARBON MONOXIDE CAN CAUSE -**

- \*DIZZINESS
- \*HEADACHE
- \*NAUSEA
- \*BODILY INJURY (BRAIN DAMAGE)
- \*DEATH BY ASPHYXIATION

**IF YOU ENCOUNTER OR SUSPECT THAT CARBON MONOXIDE IS PRESENT, GET FRESH AIR AT ONCE AND SEEK MEDICAL ATTENTION IMMEDIATELY.**

\* \* \* \* \*

**WARNING: Improper installation, adjustment, alteration, service or maintenance can cause injury or property damage. Refer to this manual. For assistance or additional information, consult a qualified installer, service agency or the gas supplier.**

# Operating The Unvented Gas Heater

## FOR YOUR SAFETY READ BEFORE LIGHTING

**WARNING:** If you do not follow these instructions exactly, a fire or explosion may result causing property damage, personal injury or loss of life.

- A. This appliance is equipped with an ignition device which manually lights the pilot.
- B. **BEFORE LIGHTING** smell all around the appliance area for gas. Be sure to smell next to the floor because some gas is heavier than air and will settle on the floor.
- WHAT TO DO IF YOU SMELL GAS**
- Do not try to light any appliance or strike a match.
  - Do not touch any electric switch; do not use any phone in your building.
  - Immediately call your gas supplier from a neighbor's phone. Follow the gas supplier's instructions.
- If you cannot reach your gas supplier, call the fire department.
- C. Use only your hand to push in or turn the gas control knob. Never use tools. If the knob will not push in or turn by hand, don't try to repair it, call a qualified service technician. Force or attempted repair may result in a fire or explosion.
- D. Do not use this appliance if any part has been under water. Immediately call a qualified service technician to inspect the appliance and to replace any part of the control system and any gas control which has been under water.

## OPERATING INSTRUCTIONS

- STOP! Read the safety information above.
- Check that gas supply to the heater is on.
- Push in gas control knob slightly and turn clockwise ↻ to "OFF".

FIGURE 11

GAS CONTROL KNOB SHOWN IN "OFF" POSITION

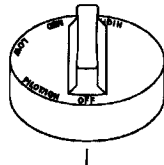

- Wait five (5) minutes to clear out any gas. Then smell for gas, including near the floor. If you smell gas, STOP! Follow "B" in the safety information above on this label. If you don't smell gas, go to the next step.
- Push in gas control knob slightly and turn counterclockwise ↺ to "PILOT/IGN" and depress for five (5) seconds.

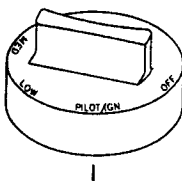
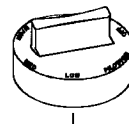

FIGURE 12

- Release control knob pressure and turn clockwise ↻ to "OFF".
- Depress control knob while OFF, then turn back to PILOT/IGN. This should cause the spark from the piezo ignitor to light the pilot gas. Keep control knob depressed for ten (10) seconds before releasing. If pilot does not light, repeat steps 5 through 7.
- To select the heating level desired, press down the control knob slightly and rotate counterclockwise ↺. Release the downward pressure on the knob, while continuing to turn, until the knob locks at the desired setting position. **DO NOT** operate between the locked positions.

FIGURE 13

(5 PLAQUE KNOB SHOWN)



(ON)

(1) PLAQUE



(3) PLAQUE



(5) PLAQUE

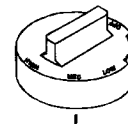

(HIGH)

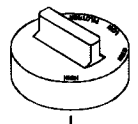
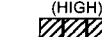

(HIGH)



# Operating The Unvented Gas Heater

## TO TURN OFF GAS TO APPLIANCE

1. Push the gas control knob in slightly and turn clockwise ↻ to "OFF". DO NOT FORCE.

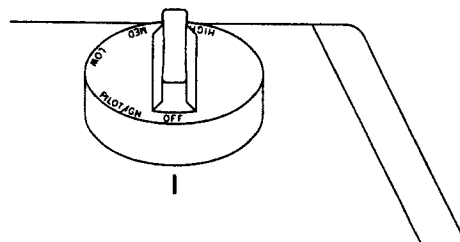

FIGURE 14

### WARNING

THE SURFACE OF THE HEATER IS HOT DURING OPERATION. KEEP CHILDREN, CLOTHING, FURNITURE AND FLAMMABLE MATERIAL AWAY FROM THE HEATER.

### WARNING

DO NOT STORE OR USE GASOLINE OR OTHER FLAMMABLE LIQUIDS OR VAPORS NEAR THE HEATER.

### WARNING

**A VISUAL CHECK OF THE BURNER PILOT FLAME SHOULD BE MADE PERIODICALLY**

Figure 15 illustrates a correct burner flame pattern. Figure 16 illustrates an incorrect burner flame pattern. The incorrect burner flame pattern shows yellow tipping of the flame.

**NOTE:** Do not mistake orange flames with yellow tipping. Dirt or other fine particles can enter the heater and burn, causing brief patches of orange flame.

### WARNING

IF YELLOW TIPPING OCCURS, YOUR HEATER COULD PRODUCE INCREASED LEVELS OF CARBON MONOXIDE. IF BURNER FLAME PATTERN SHOWS YELLOW TIPPING, SEE "TROUBLESHOOTING" SECTION OF THIS MANUAL.

FIGURE 15

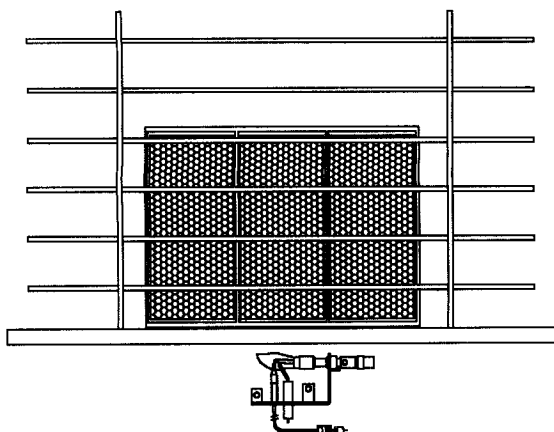

NORMAL

FIGURE 16

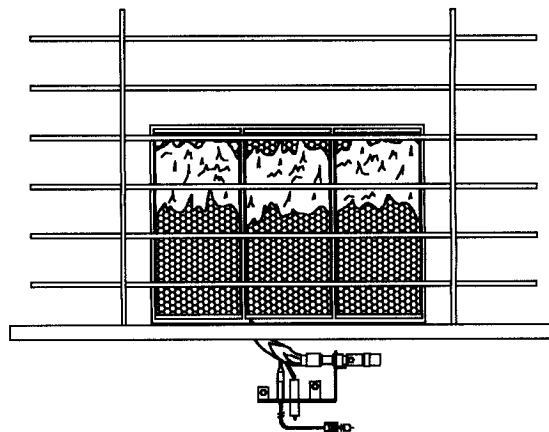

ABNORMAL

# Operating The Unvented Gas Heater

## FOR YOUR SAFETY READ BEFORE LIGHTING

**WARNING:** If you do not follow these instructions exactly, a fire or explosion may result causing property damage, personal injury or loss of life.

- A. This appliance is equipped with an ignition device which manually lights the pilot.
- If you cannot reach your gas supplier, call the fire department.
- B. **BEFORE LIGHTING** smell all around the appliance area for gas. Be sure to smell next to the floor because some gas is heavier than air and will settle on the floor.
- C. Use only your hand to push in or turn the gas control knob. Never use tools. If the knob will not push in or turn by hand, don't try to repair it, call a qualified service technician. Force or attempted repair may result in a fire or explosion.
- D. Do not use this appliance if any part has been under water. Immediately call a qualified service technician to inspect the appliance and to replace any part of the control system and any gas control which has been under water.

### WHAT TO DO IF YOU SMELL GAS

- Do not try to light any appliance or strike a match.
- Do not touch any electric switch; do not use any phone in your building.
- Immediately call your gas supplier from a neighbor's phone. Follow the gas supplier's instructions.

## OPERATING INSTRUCTIONS

- STOP! Read the safety information above.
- Check that gas supply to the heater is on.
- Push in ignition knob slightly and turn clockwise ↻ to "OFF".

FIGURE 17

IGNITION KNOB SHOWN IN "OFF" POSITION

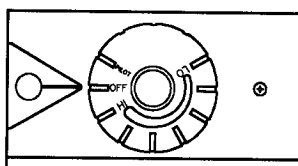

- Wait five (5) minutes to clear out any gas. Then smell for gas, including near the floor. If you smell gas, STOP! Follow "B" in the safety information above on this label. If you don't smell gas, go to the next step.
- Push in ignition knob slightly and turn counterclockwise ↶ to "PILOT" and depress for five (5) seconds.

FIGURE 18

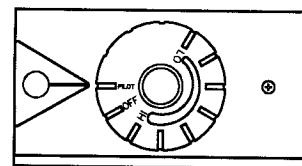

- Release ignition knob pressure and turn clockwise ↻ to "OFF".
- Depress ignition knob while "OFF", then turn back to "PILOT". This should cause the spark from the piezo ignitor to light the pilot gas. Keep ignition knob depressed for ten (10) seconds before releasing. If pilot does not light, repeat steps 5 through 7.
- When pilot is lit, turn the ignition knob to select the heating level desired (LO-HI).

FIGURE 19

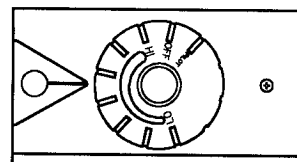

# Operating The Unvented Gas Heater

## TO TURN OFF GAS TO APPLIANCE

1. Push the gas ignition knob in slightly and turn clockwise  to "OFF". DO NOT FORCE.

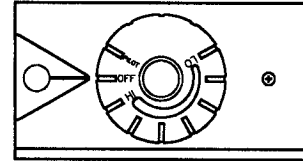

FIGURE 20

### WARNING

THE SURFACE OF THE HEATER IS HOT DURING OPERATION. KEEP CHILDREN, CLOTHING, FURNITURE AND FLAMMABLE MATERIAL AWAY FROM THE HEATER.

### WARNING

DO NOT STORE OR USE GASOLINE OR OTHER FLAMMABLE LIQUIDS OR VAPORS NEAR THE HEATER.

### WARNING

**A VISUAL CHECK OF THE BURNER PILOT FLAME SHOULD BE MADE PERIODICALLY**

Figure 21 illustrates a correct burner flame pattern. Figure 22 illustrates an incorrect burner flame pattern. The incorrect burner flame pattern shows yellow tipping of the flame.

**NOTE:** Do not mistake orange flames with yellow tipping. Dirt or other fine particles can enter the heater and burn, causing brief patches of orange flame.

### WARNING

IF YELLOW TIPPING OCCURS, YOUR HEATER COULD PRODUCE INCREASED LEVELS OF CARBON MONOXIDE. IF BURNER FLAME PATTERN SHOWS YELLOW TIPPING, SEE "TROUBLESHOOTING" SECTION OF THIS MANUAL.

FIGURE 21

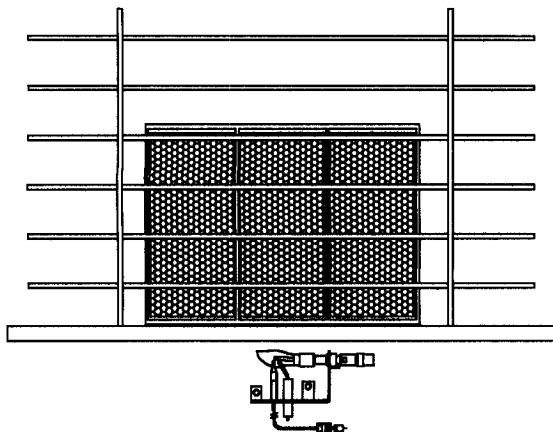

NORMAL

FIGURE 22

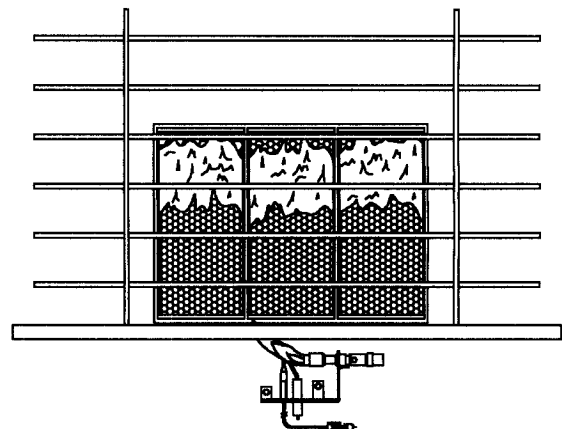

ABNORMAL

# How To Care For Your Unvented Gas Heater

## WARNING

DANGER OF BODILY INJURY OR DEATH

### IF FAN KIT ACCESSORY IS USED:

TURN OFF ELECTRIC POWER SUPPLY AT DISCONNECT SWITCH, FUSE BOX OR SERVICE PANEL BEFORE REMOVING ANY DOORS OR ACCESS/SERVICE PANELS FROM UNIT.

Service, repair or maintenance of the unvented heating system should only be attempted by a qualified service technician. The burner and control of the heater should be cleaned and checked at least once each year by a qualified service technician. If there is any indication that the heater is operating improperly, turn it off and have it checked immediately. Lint and dust may be vacuumed from the interior of the heater, when it is cool. The control and main burner can be blown free of dust and lint with a vacuum cleaner or pressurized air.

## ANNUAL UPKEEP NEEDED

It is recommended that a qualified service technician inspect the heater annually.

## CABINET

Clean cabinet with damp cloth. Never use abrasive cleaners. Cabinets are finished in heat resistant baked enamel. DO NOT refinish with wall paint.

## ODS PILOT AND BURNER

Use a vacuum cleaner, pressurized air, or small, soft bristled brush to clean the ODS pilot and burner. Never use a wire, needle or similar object to clean ODS pilot. This could damage the ODS pilot unit.

Keep all combustible materials, gasoline and other flammable liquids or vapors away from this heater. Be sure that combustion and ventilation air openings supplying this heater are kept clear at all times.

Continued safe and satisfactory performance of this heater requires, but is not limited to, periodic examination of the pilot flame, combustion chamber, liners and gas supply lines, and periodic cleaning of the burner air intake, pilot and control areas.

## INSPECTING PILOT

Figure 23 illustrates a correct pilot flame pattern. Figure 24 illustrates an incorrect pilot flame pattern. The incorrect pilot flame is not touching the thermocouple. This causes the thermocouple to cool and the heater to shut down. If the pilot flame pattern is incorrect:

- \* turn the heater off (see "Turn Off Gas to Appliance" on pages 13 and 15).
- \* see "Troubleshooting" on pages 17-19.

FIGURE 23

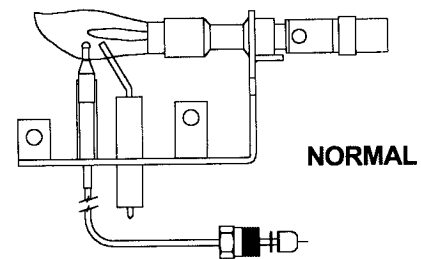
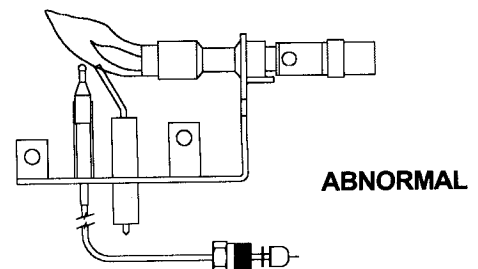

FIGURE 24



# Troubleshooting Unvented Gas Heater

SYMPTOM	POSSIBLE CAUSE	CORRECTIVE ACTION
1. No spark at O.D.S. pilot when ignitor button is pressed.	A. Ignitor electrode positioned wrong.	Replace O.D.S. pilot assembly.
	B. Ignitor electrode broken.	Replace O.D.S. pilot assembly.
	C. Ignitor electrode not connected to ignitor cable.	Reconnect ignitor cable.
	D. Ignitor cable pinched or wet.	Free ignitor cable if pinched. Keep dry.
	E. Piezo ignitor is loose.	Press Piezo ignitor to valve located inside heater cabinet top.
	F. Broken ignitor cable.	T-stat models - Replace ignitor cable. Manual models - Replace valve.
	G. Bad Piezo ignitor.	T-stat models - Replace Piezo ignitor. Manual models - Replace valve.
2. Spark at O.D.S. pilot but no ignition when ignitor button is pressed.	A. Gas supply turned off or manual shutoff valve closed.	Turn on gas supply or open manual shutoff valve.
	B. Control knob not in PILOT position.	Turn control knob to PILOT position.
	C. Control knob not pressed in while in PILOT position.	Press in control knob while in PILOT position.
	D. Air in gas lines when installed.	Hold down control knob. Repeat igniting operation until air is removed.
	E. O.D.S. pilot is clogged.	Clean O.D.S. pilot or replace ODS pilot assembly.
	F. Gas regulator setting not correct.	Replace gas regulator.
3. Pilot is lit but burner does not ignite.	A. Burner orifice is clogged.	Clean burner or replace burner orifice.
	B. Inlet gas pressure is too low.	Contact local gas company.
4. Delayed ignition of burner.	A. Manifold pressure is too low.	Contact local gas company. Replace regulator.
	B. Burner orifice is clogged.	Clean burner.

## Troubleshooting Unvented Gas Heater cont.

SYMPTOM	POSSIBLE CAUSE	CORRECTIVE ACTION
5. O.D.S. pilot lights but does not remain lit when control knob is released.	A. Control knob not fully pressed in.	Press control knob in fully.
	B. Control knob not pressed in long enough.	After ODS pilot lights, keep control knob pressed in 30 seconds.
	C. Safety interlock system has been triggered.	Wait one (1) minute for safety interlock system to reset. Repeat ignition operation.
	D. Manual shutoff valve not fully open.	Open valve.
	E. Thermocouple connection loose at control valve.	Hand tighten until snug, then tighten 1/4 turn more.
	F. Low gas pressure.	Contact local gas company.
	G. Dirty or clogged ODS pilot.	Clean ODS pilot or replace ODS pilot assembly.
	H. Thermocouple damaged.	Replace O.D.S. pilot assembly.
	I. Control valve damaged.	Replace.
6. Burner backfiring during combustion.	A. Burner orifice is clogged or damaged.	Clean burner or replace burner orifice.
	B. Burner damaged.	Replace.
	C. Gas regulator defective.	Replace.
7. Yellow flame during burner combustion. Do not operate in this condition. See Carbon Monoxide warning on page 10.	A. Not enough air.	Check burner for dirt. Clean.
	B. Gas regulator defective.	Replace gas regulator.
8. Slight smoke or odor during initial operation.	A. Residues from manufacturing processes.	Problem will stop after a few hours of operation.
9. Heater produces a clicking/ticking noise just after burner is lit or shut off.	A. Metal expanding while heating or contracting while cooling.	This is common in most heaters. If noise is excessive, contact qualified service technician.
10. Heater produces unwanted odors.	A. Heater burning vapors from paint, hair spray, glue, etc.	Ventilate room. Stop using odor causing products while heater is on.
	B. Gas leak.	Locate and correct all leaks.

## Troubleshooting Unvented Gas Heater cont.

SYMPTOM	POSSIBLE CAUSE	CORRECTIVE ACTION
11. Gas odor even when control knob is in OFF position.	A. Gas leak.	Locate and correct all leaks.
	B. Control valve defective.	Replace.
12. Excessive moisture on windows and other surfaces.	A. Heater is oversized for the area in which it is installed.	Add more combustion air to the room.
	B. Not enough fresh air available.	Add more combustion air to the room.
13. Heater shuts off while in use but ODS operates.	A. Not enough fresh air available.	Open window and/or door for ventilation.
	B. Low line pressure.	Contact local gas company.
	C. ODS pilot is partially clogged.	Clean ODS pilot.
14. When burner is lit, heater makes a whistling noise.	A. Turning control knob to HI position when burner is cold.	Turn control knob to LO position and let burner warm up.
	B. Air in gas line.	Operate burner until air is removed from line. Have gas line checked by local gas company.
	C. Air passageways on heater blocked.	Check minimum installation clearances.
	D. Dirty or clogged burner orifice.	Clean burner.

# WILLIAMS INFRARED UNVENTED GAS HEATER

**REPLACEMENT PARTS FOR MODELS  
0556542; 0556541; 1556511; 1556541; 1856512;  
1856542; 2556511; 2556541; 3056512; 3056542;**

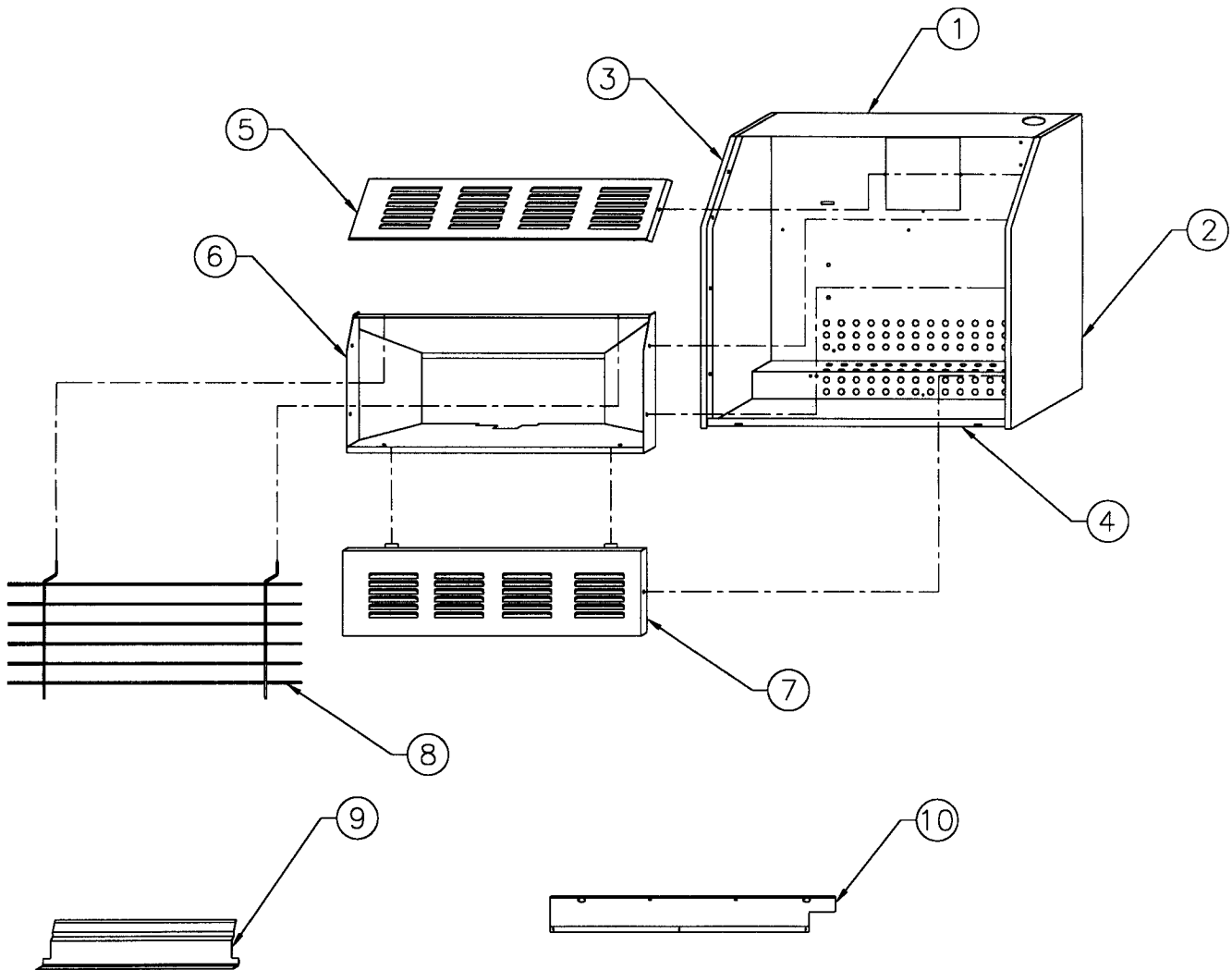

USE ONLY MANUFACTURER'S REPLACEMENT PARTS

FOR PARTS LIST SEE PAGE 21

## WILLIAMS INFRARED UNVENTED GAS HEATER

### REPLACEMENT PARTS LIST FOR MODELS 0556541; 0556542; 1556511; 1556541; 1856512; 1856542; 2556511; 2556541; 3056512; 3056542

REF. NO.	PART NO.	DESCRIPTION	0556541; 0556542	1556511; 1856541; 1856542	1556511; 1856512	2556541; 3056542	2556511; 3056512
1	26B155	TOP PANEL ASSEMBLY, SMALL	X				
1	26B156	TOP PANEL ASSEMBLY, MEDIUM		X			
1	26D003-1	TOP PANEL, MEDIUM			X		
1	26B157	TOP PANEL ASSEMBLY, LARGE				X	
1	26D004-1	TOP PANEL, LARGE					X
2	26D002-2	RIGHT SIDE PANEL	X				
2	26D001-2	RIGHT SIDE PANEL		X	X	X	X
3	26D002-1	LEFT SIDE PANEL	X				
3	26D001-1	LEFT SIDE PANEL		X	X	X	X
4	26C001	BACK PANEL	X				
4	26C002	BACK PANEL		X	X		
4	26C003	BACK PANEL				X	X
5	26B002	TOP FRONT PANEL	X				
5	26B003	TOP FRONT PANEL		X	X		
5	26B004	TOP FRONT PANEL				X	X
6	26B095	HEARTH ASSEMBLY, SMALL INFRARED	X				
6	26B096	HEARTH ASSEMBLY, MEDIUM INFRARED		X	X		
6	26B097	HEARTH ASSEMBLY, LARGE INFRARED				X	X
7	26B005	BOTTOM FRONT PANEL	X				
7	26B006	BOTTOM FRONT PANEL		X	X		
7	26B007	BOTTOM FRONT PANEL				X	X
8	P322743	FRONT SCREEN	X				
8	P322745	FRONT SCREEN		X	X		
8	P322747	FRONT SCREEN				X	X
9	26A001	DEFLECTOR	X				
9	26A002	DEFLECTOR		X	X		
9	26A003	DEFLECTOR				X	X
10	26B053-3	HEAT SHIELD	X				
10	26B053-2	HEAT SHIELD		X	X		
10	26B053-1	HEAT SHIELD				X	X

SEE PAGE 20 FOR PARTS ILLUSTRATION

# WILLIAMS INFRARED UNVENTED GAS HEATER

## REPLACEMENT PARTS FOR MODELS 0556541; 0556542

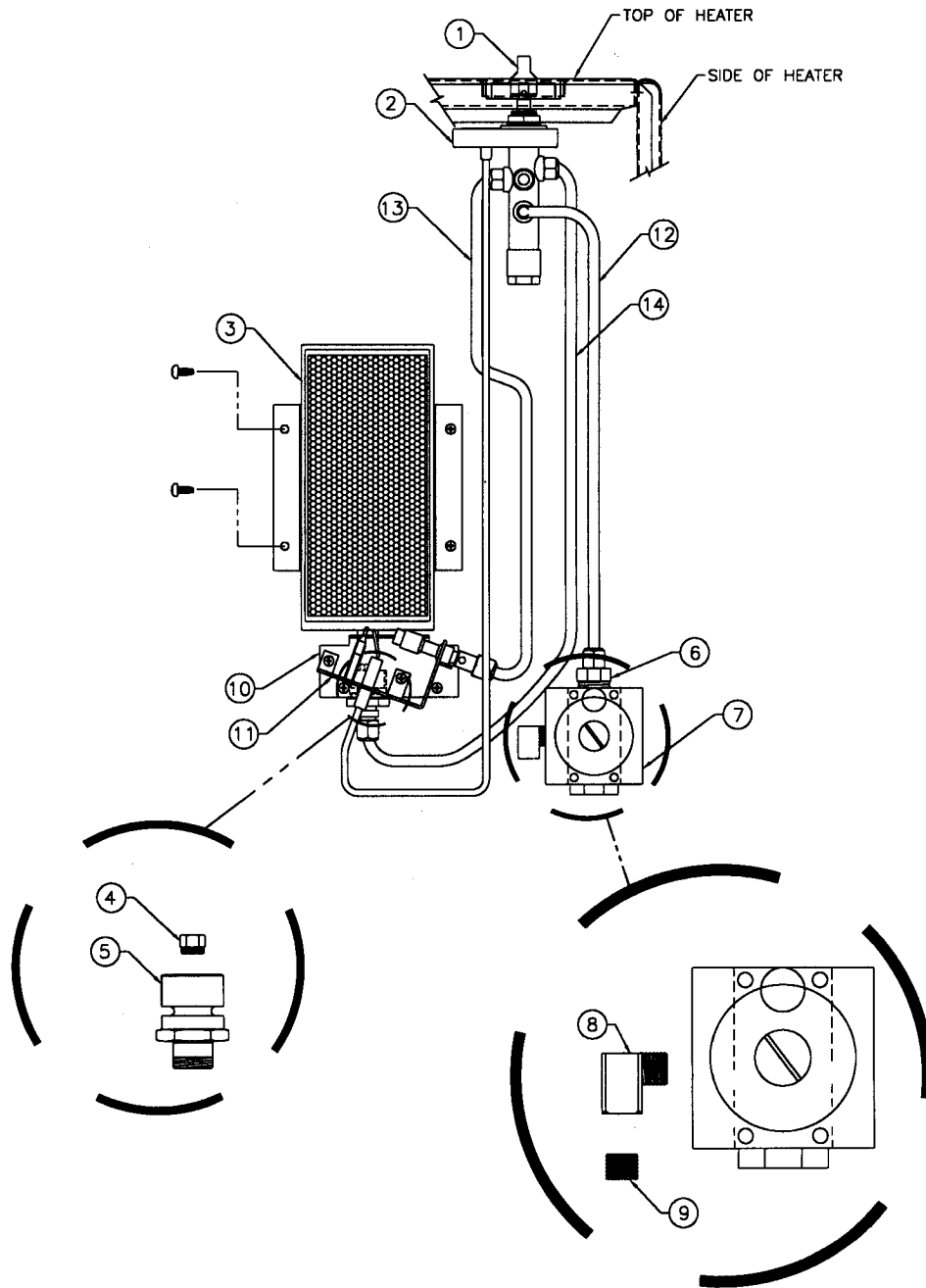

USE ONLY MANUFACTURER'S REPLACEMENT  
PARTS

FOR PARTS LIST SEE PAGE 27

# WILLIAMS INFRARED UNVENTED GAS HEATER

## REPLACEMENT PARTS FOR MODEL 1556541; 1856542

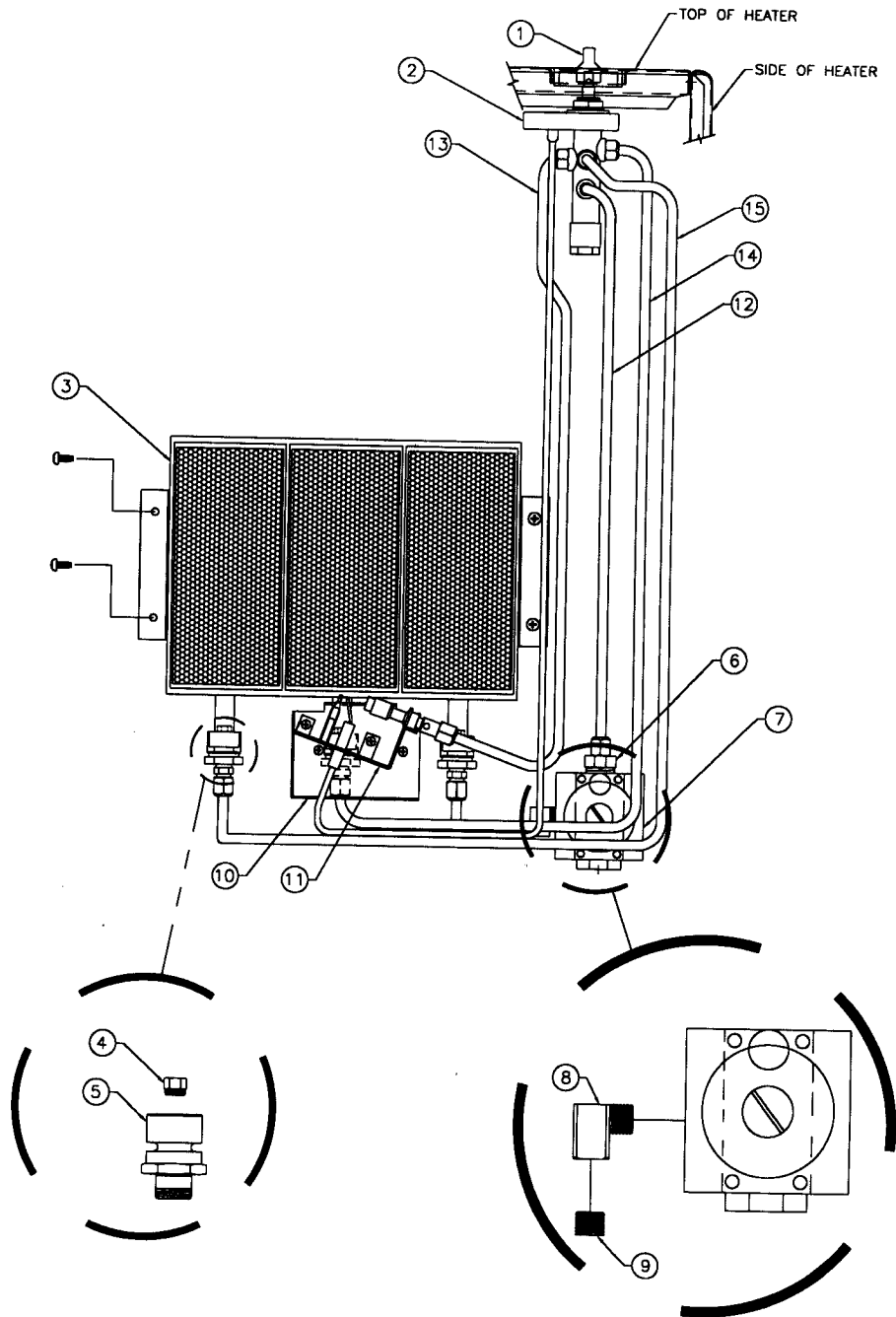

USE ONLY MANUFACTURER'S REPLACEMENT  
PARTS

FOR PARTS LIST SEE PAGE 27

# WILLIAMS INFRARED UNVENTED GAS HEATER

## REPLACEMENT PARTS FOR MODEL 2556541; 3056542

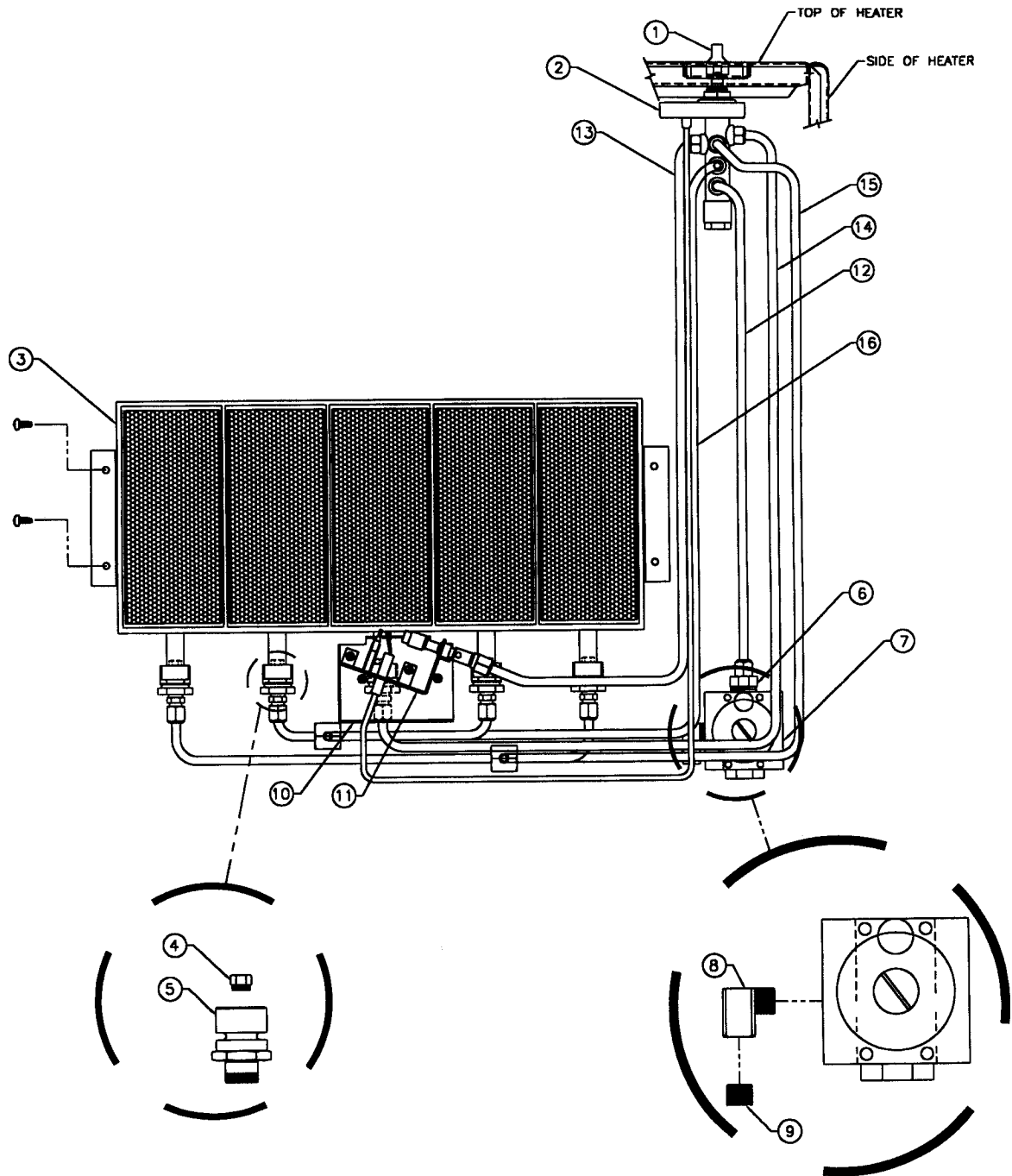

USE ONLY MANUFACTURER'S REPLACEMENT  
PARTS

FOR PARTS LIST SEE PAGE 27

# WILLIAMS INFRARED UNVENTED GAS HEATER

## REPLACEMENT PARTS FOR MODEL 1556511; 1856512

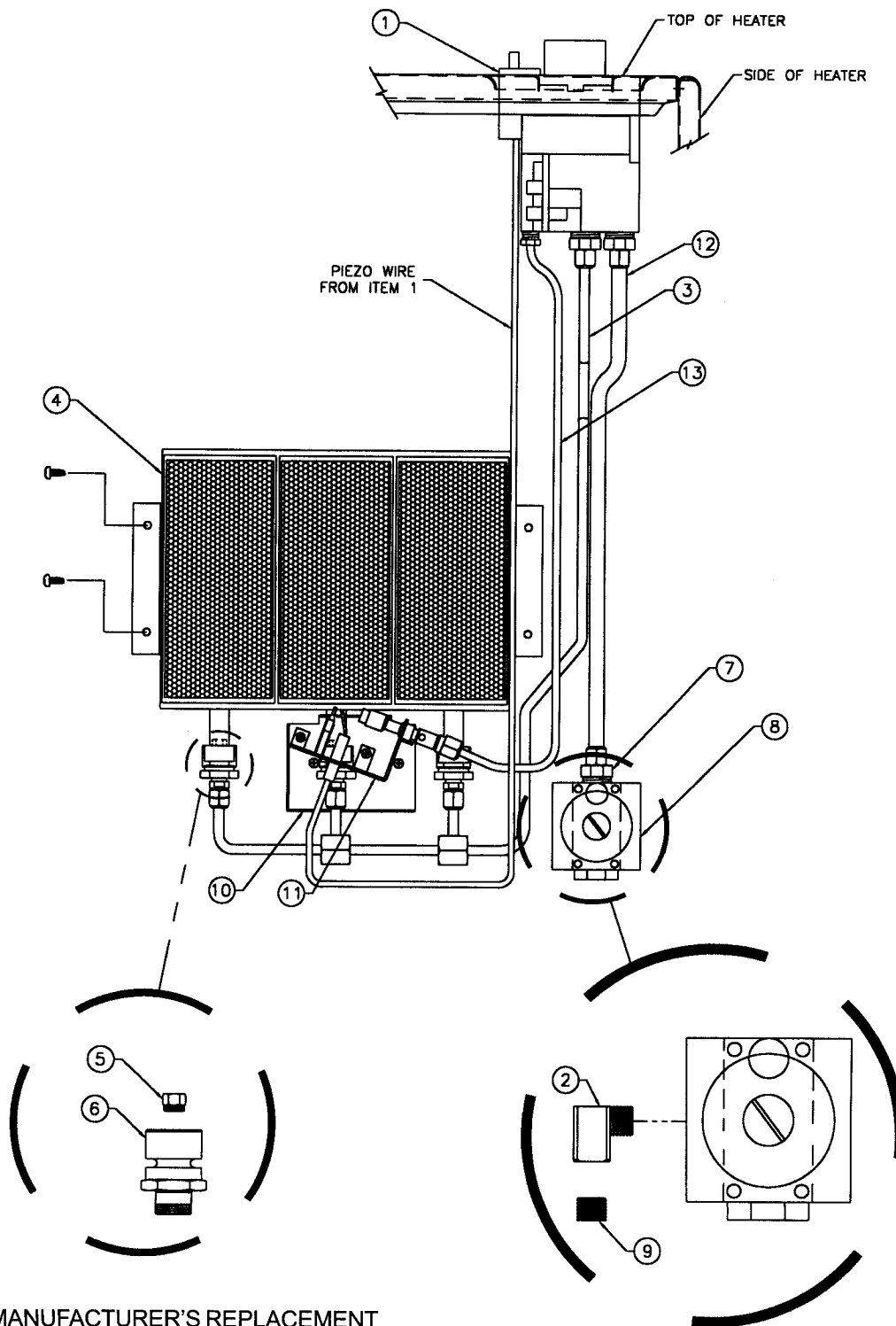

USE ONLY MANUFACTURER'S REPLACEMENT  
PARTS

FOR PARTS LIST SEE PAGE 28

# WILLIAMS INFRARED UNVENTED GAS HEATER

## REPLACEMENT PARTS FOR MODEL 2556511; 3056512

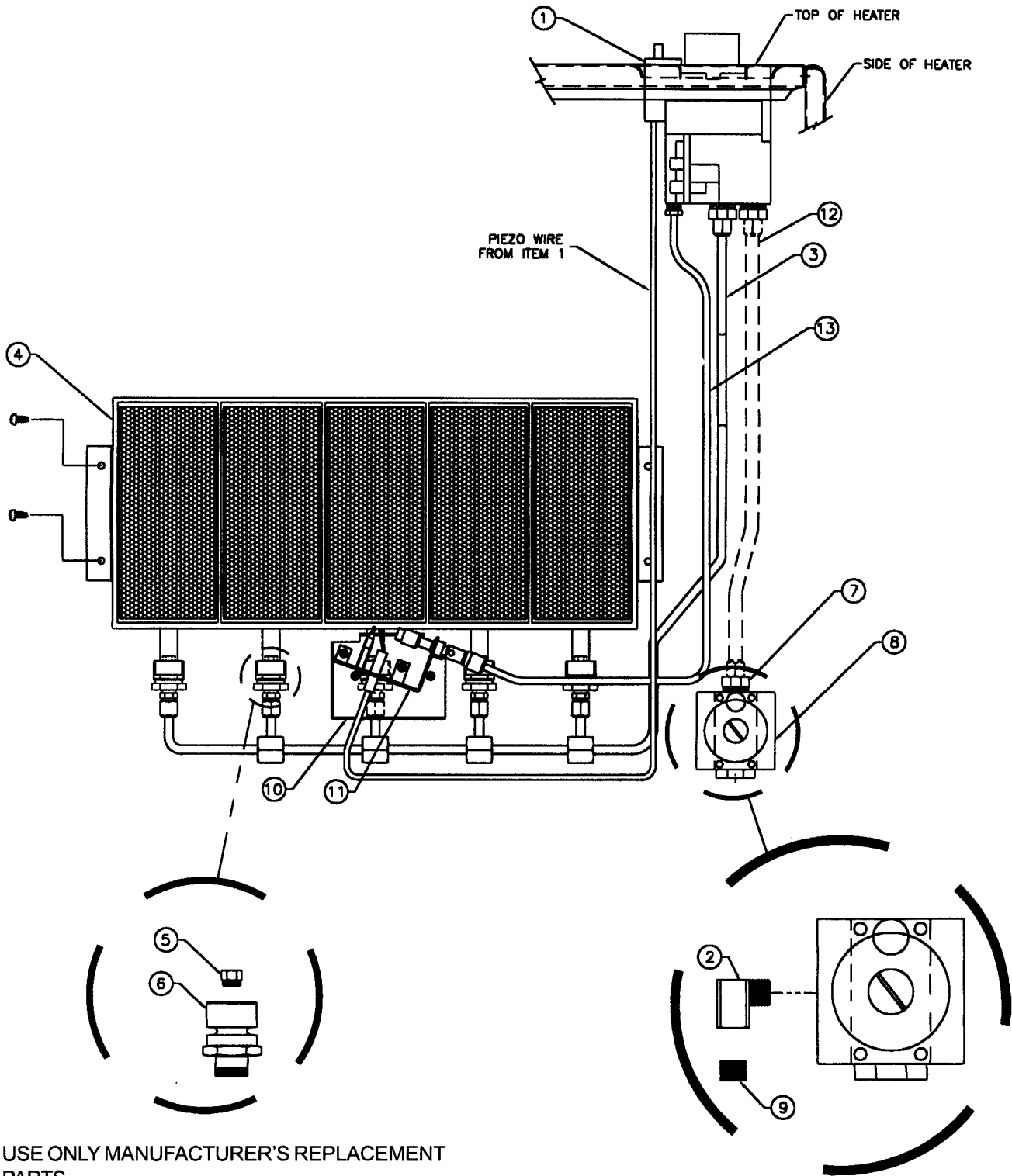

USE ONLY MANUFACTURER'S REPLACEMENT PARTS

FOR PARTS LIST SEE PAGE 28

# WILLIAMS INFRARED UNVENTED GAS HEATER

## REPLACEMENT PARTS LIST FOR MODELS

0556542; 0556541; 1856542; 1556542;  
3056542; 2556541

REF. NO.	PART NO.	DESCRIPTION	0556542	0556541	1856542	1556541	3056542	2556541
1	P322658	KNOB	X	X				
1	P322657	KNOB			X	X		
1	P322656	KNOB					X	X
2	P322740	VALVE	X	X				
2	P322741	VALVE			X	X		
2	P322742	VALVE					X	X
3	P322891	PLAQUE BURNER	X	X				
3	P322890	PLAQUE BURNER			X	X		
3	P322889	PLAQUE BURNER					X	X
4	P323158	ORIFICE	X					
4	P323157	ORIFICE			X			
4	P323156	ORIFICE					X	
4	P323171	ORIFICE		X		X		X
5	P322908	ORIFICE HOLDER	X	X	X	X	X	X
6	P322918	3/8" FITTING	X	X	X	X	X	X
7	P322898	REGULATOR	X		X		X	
7	P322899	REGULATOR		X		X		X
8	P322903	STREET ELBOW	X	X	X	X	X	X
9	P323018	REGULATOR PLUG	X	X	X	X	X	X
10	26A008	PILOT BRACKET	X					
10	26A007	PILOT BRACKET		X	X	X	X	X
11	P322892	O.D.S. PILOT	X		X		X	
11	P323220	O.D.S. PILOT		X		X		X
12	26B042	REGULATOR TUBE ASSEMBLY	X	X				
12	26B045	REGULATOR TUBE ASSEMBLY			X	X	X	X
13	26B044	PILOT TUBE ASSEMBLY	X	X				
13	26B052	PILOT TUBE ASSEMBLY			X	X		
13	26B049	PILOT TUBE ASSEMBLY					X	X
14	26B043	BURNER TUBE ASSEMBLY	X	X				
14	26B050	BURNER TUBE ASSEMBLY			X	X		
14	26B046	BURNER TUBE ASSEMBLY					X	X
15	26B051	BURNER TUBE ASSEMBLY			X	X		
15	26B048	BURNER TUBE ASSEMBLY					X	X
16	26B047	BURNER TUBE ASSEMBLY					X	X

SEE PAGES 22-24 FOR PARTS ILLUSTRATIONS

# WILLIAMS INFRARED UNVENTED GAS HEATER

## REPLACEMENT PARTS LIST FOR MODELS

1556511; 1856512;  
2556511; 3056512

REF. NO.	PART NO.	DESCRIPTION	1856512	1556511	3056512	2556511
1	26C007-7	VALVE ASSEMBLY	X	X	X	X
2	P322903	STREET ELBOW	X	X	X	X
3	26B038	BURNER TUBE ASSEMBLY	X	X		
3	26B039	BURNER TUBE ASSEMBLY			X	X
4	P322890	PLAQUE BURNER	X	X		
4	P322889	PLAQUE BURNER			X	X
5	P323157	ORIFICE	X			
5	P323156	ORIFICE			X	
5	P323171	ORIFICE		X		X
6	P322908	ORIFICE HOLDER	X	X	X	X
7	P322919	3/8" FITTING	X	X	X	X
8	P322898	REGULATOR	X		X	
8	P322899	REGULATOR		X		X
9	P323018	REGULATOR PLUG	X	X	X	X
10	26A007	PILOT BRACKET	X	X	X	X
11	P322892	O.D.S. PILOT	X		X	
11	P323220	O.D.S. PILOT		X		X
12	26B028	REGULATOR TUBE ASSEMBLY	X	X	X	X
13	26B041	PILOT TUBE ASSEMBLY	X	X		
13	26B040	PILOT TUBE ASSEMBLY			X	X

SEE PAGES 25-26 FOR PARTS ILLUSTRATIONS

# INSTALLATION INSTRUCTIONS for BLOWER ACCESSORIES 2205 - T-STAT & 2206 - MANUAL

**STEP 1: WALL MOUNTED HEATERS ONLY** - TURN OFF GAS SUPPLY. DISCONNECT UNIT FROM GAS SUPPLY AND WALL BEFORE INSTALLING BLOWER.

**STEP 2: REMOVE BACK PLATE FROM UNIT BY UNSCREWING FOUR (4) SCREWS. RETAIN FOUR (4) SCREWS FOR INSTALLATION OF BLOWER. DISCARD BACK PLATE.**

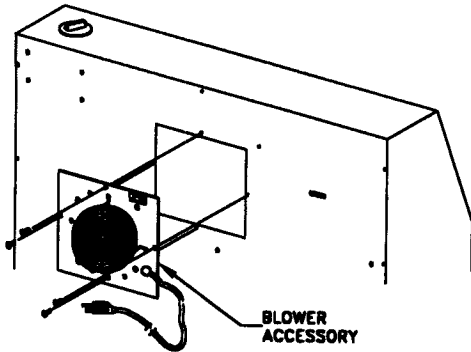
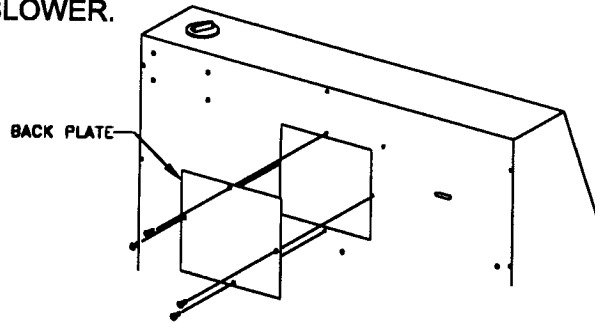

**STEP 3: INSTALL BLOWER AS SHOWN IN THE ILLUSTRATION. USE THE FOUR (4) SCREWS RETAINED TO MOUNT BLOWER TO BACK PANEL.**

**STEP 4: THE BLOWER ASSEMBLY IS EQUIPPED WITH A THREE (3) PRONG, 7 FOOT POWER CORD. USE A STANDARD THREE (3) HOLE GROUNDED OUTLET. IF AN EXTENSION CORD IS NEEDED, USE A STANDARD THREE (3) PRONG GROUNDED CORD WITH A THREE (3) HOLE RECEPTACLE.**

## **STEP 5: BLOWER OPERATION**

### **BLOWER ACCESSORY 2205 - T-STAT**

SWITCH BLOWER ON/OFF SWITCH TO "ON" POSITION. TURN HEATER ON. BLOWER WILL CYCLE "ON" OR "OFF" AS THE THERMOSTAT HEATS AND COOLS TO DESIRED TEMPERATURE. TURN THE HEATER OFF AND THE BLOWER WILL AUTOMATICALLY TURN OFF, OR SWITCH THE BLOWER ON/OFF SWITCH TO THE "OFF" POSITION.

### **BLOWER ACCESSORY 2206 - MANUAL**

SWITCH BLOWER "ON" OR "OFF" AS NEEDED WITH BLOWER ON/OFF SWITCH.

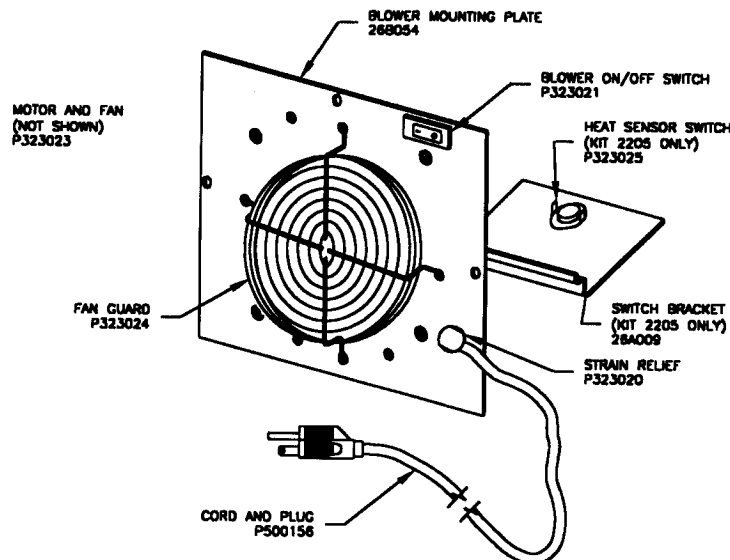

**THIS UNIT MUST BE GROUNDED FOR YOUR PROTECTION AGAINST ELECTRICAL SHOCK.**

# INSTALLATION INSTRUCTIONS for FLOOR BASE ACCESSORIES 4287 & 4288

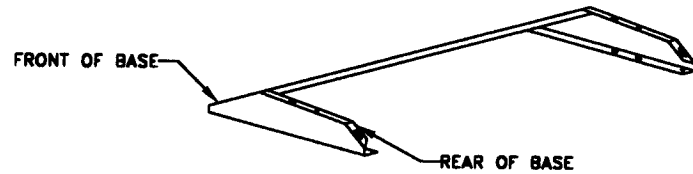

**STEP 1:** LAY HEATER ON ITS BACK (SEE ILLUSTRATION BELOW). LOOSEN TWO (2) SCREWS, LOCATED ON BOTTOM OF HEATER - DO NOT REMOVE SCREWS.

**STEP 2:** ATTACH FLOOR BASE TO HEATER WITH TWO (2) KEYHOLES LOCATED ON TOP OF THE FLOOR BASE. TIGHTEN SCREWS.

USE TWO (2) SCREWS, INCLUDED WITH KIT, TO ATTACH BACK OF FLOOR BASE TO THE BOTTOM BACK OF HEATER.

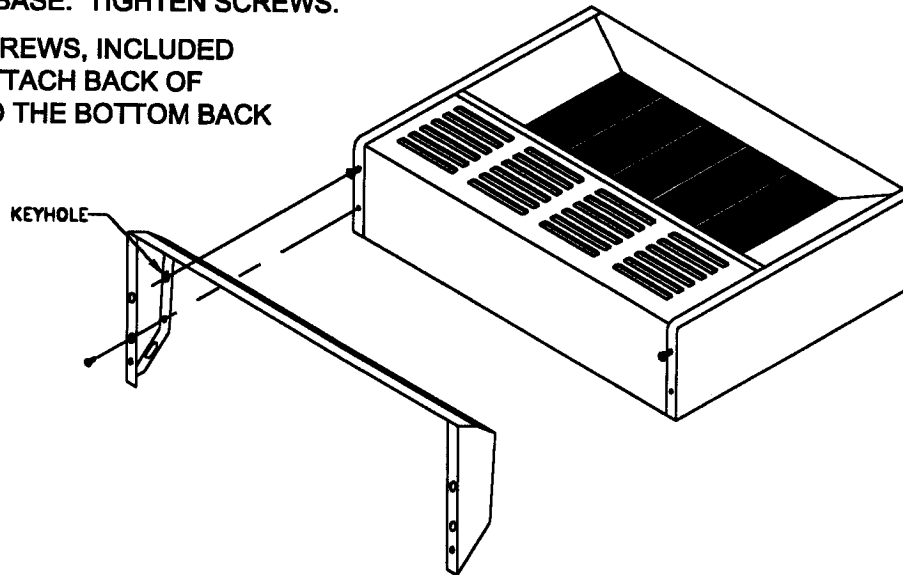

**STEP 3:** STAND HEATER UPRIGHT. SELECT LOCATION OF HEATER. REFER TO THE INSTALLATION AND OPERATING INSTRUCTION MANUAL FOR MINIMUM CLEARANCES.

CONNECT GAS PIPING. SEE SECTION "GAS SUPPLY AND PIPING REQUIREMENTS" IN THE INSTALLATION AND OPERATING INSTRUCTION MANUAL.

USE TWO (2) FLOOR MOUNTING SCREWS, (NOT INCLUDED WITH KIT), TO MOUNT THE BOTTOM BACK OF THE FLOOR BASE TO THE FLOOR (SEE ILLUSTRATION ABOVE).

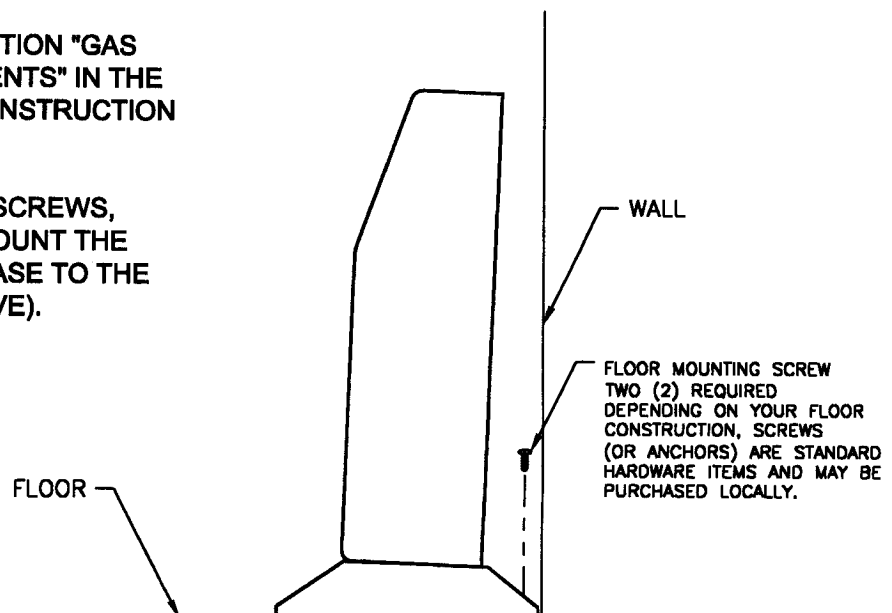



**owners  
manual**

**MODEL NOS.**

**0556542  
1856512  
1856542  
3056512  
3056542**

**NATURAL GAS ONLY**

**0556541  
1556511  
1556541  
2556511  
2556541**

**LIQUEFIED PETROLEUM (L.P.)  
GAS ONLY**

**SERVICE HINTS**

If your unvented heater fails to work right, you may avoid inconvenience and the cost of a service call by checking the "Troubleshooting" section of this manual on pages 16-18 before calling for service.

FOR YOUR SAFETY	FOR YOUR SAFETY
Do not store or use gasoline or other flammable vapors and liquids in the vicinity of this or any other appliance.	This appliance should be inspected before use and at least once a year by a qualified service person. Installation and repairs must be done by a qualified service person.

**Specifications**

Model No.	BTU	Max. Supply Pressure	Min. Gas Inlet Pressure	Pressure	Manifold Dimensions	Weight
0556542	5,000	10"W.C.	6"W.C.	5"W.C.	5 1/4 X 13 3/4 X 18 1/8	16
0556541	5,000	14"W.C.	11"W.C.	10"W.C.	5 1/4 X 13 3/4 X 18 1/8	16
1556511	15,000	14"W.C.	11"W.C.	10"W.C.	6 7/8 X 18 5/8 X 23 1/8	26
1556541	5,000-15,000	14"W.C.	11"W.C.	10"W.C.	6 7/8 X 18 5/8 X 23 1/8	26
1856512	18,000	10"W.C.	6"W.C.	5"W.C.	6 7/8 X 18 5/8 X 23 1/8	26
1856542	6,000-18,000	10"W.C.	6"W.C.	5"W.C.	6 7/8 X 18 5/8 X 23 1/8	26
2556511	25,000	14"W.C.	11"W.C.	10"W.C.	6 7/8 X 26 1/8 X 23 1/8	34
2556541	5,000-25,000	14"W.C.	11"W.C.	10"W.C.	6 7/8 X 26 1/8 X 23 1/8	34
3056512	28,000	10"W.C.	6"W.C.	5"W.C.	6 7/8 X 26 1/8 X 23 1/8	34
3056542	6,000-28,000	10"W.C.	6"W.C.	5"W.C.	6 7/8 X 26 1/8 X 23 1/8	34

**How To Order Repair Parts**

When ordering repair parts, always give the following information:

1. MODEL NUMBER
2. MFG. DATE CODE
3. PART NUMBER
4. PART DESCRIPTION

All parts listed herein may be ordered from your equipment supplier.

The Model Number of your Williams unvented heater will be found on the rating plate on the inside bottom of the cabinet.



**WILLIAMS FURNACE COMPANY**  
225 Acacia Street  
Colton, CA 92324 USA  
(909) 825-0993

MANUFACTURED  
IN THE U.S.A.  
Established 1916  
FAX: (909) 824-8009